



BASIC FEATURES

DAPHNE FLAT is a highly energy-efficient heat recovery unit designed for either ceiling or wall mounting installation and thanks to its super-low profile the unit is highly convenient for interiors with limited space. DAPHNE FLAT is designed for installations in residential premises such as **family houses, apartment buildings, low-energy and passive houses.**

- Nominal airflow **350, 520, 770 m³/h** (at 100Pa)
- Energy class **A / A+**
- **Super quiet** operation
- Ceiling and Wall installation
- Slim profile convenient for use in premises with limited space
- Energy-efficient EC fans with low SFP and quiet operation
- Aluminium counterflow heat exchanger with recovery efficiency up to 96% (EN308)
- Stepless fully automatic bypass-damper control (temperature control, free-cooling, anti-freeze protection)
- AirGENIO COMFORT control system integrated
- CAV or DCV ventilation based on AQS sensors (CO₂, RH, VOC)
- BMS control via ModBUS RTU, ModBUS TCP or BACnet
- Control via Smart Device
- Easy installation and maintenance

The unit is designed to be operated in a dry indoor environment (relative humidity not exceeding 80%) and at an ambient temperature in the range from +5°C up to +40°C.

The unit is designed for transporting standard atmospheric air that is free of dust, grease, chemical emissions and other impurities.

The unit has an IP rating of IP 20.

It is recommended that the heat recovery project always be designed by a qualified HVAC designer, engineer or architect.

OPERATIONAL DIAGRAM

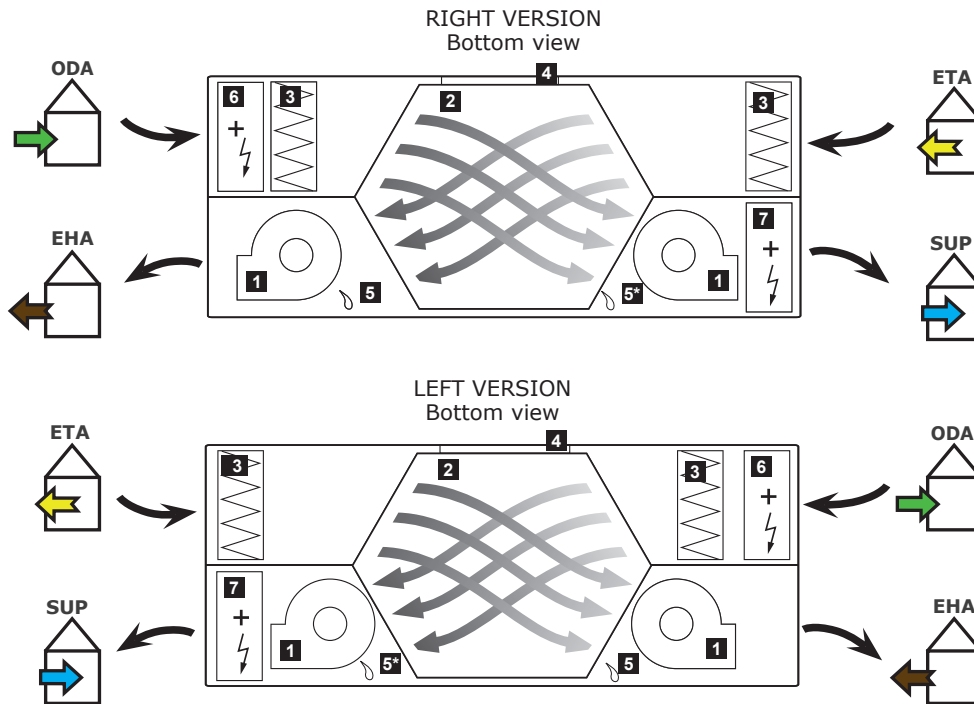

- 1 - Fan
- 2 - Heat exchanger with by-pass flap
- 3 - Air filter
- 4 - Electrical connection (control box)
- 5 - Condensate drain
- 5* - Second condensate drain in places where summer conditions require it
- 6 - Electric preheater
- 7 - Electric post heater



PRIMARY PARAMETERS

Heat recovery efficiency

According to EN13141-7 (with a balanced mass flow)
 Temperature - Supply in 7°C, Relative humidity - supply in 80%
 Temperature - Exhaust in 20°C, Relative humidity - exhaust in 38%

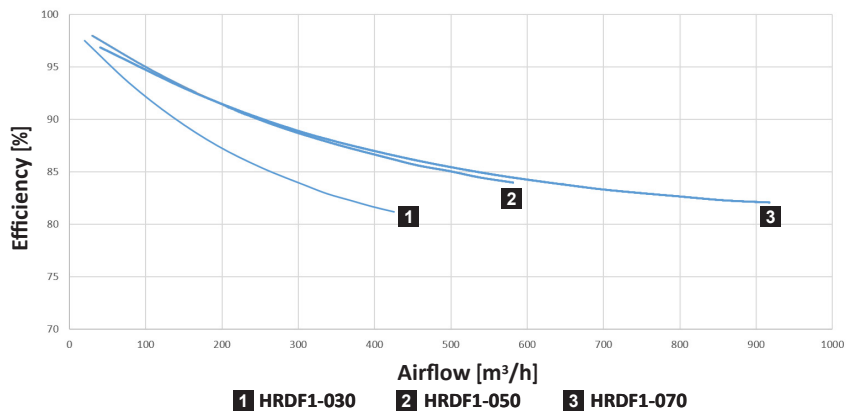

COMMISSION DELEGATED REGULATION (EU) No 1254/2014

Type	Class
HRDF1-030	A
HRDF1-050	A+
HRDF1-070	A+



SFP=Unit Power input (two fans) (kW/m³/s)

HRDF1-030

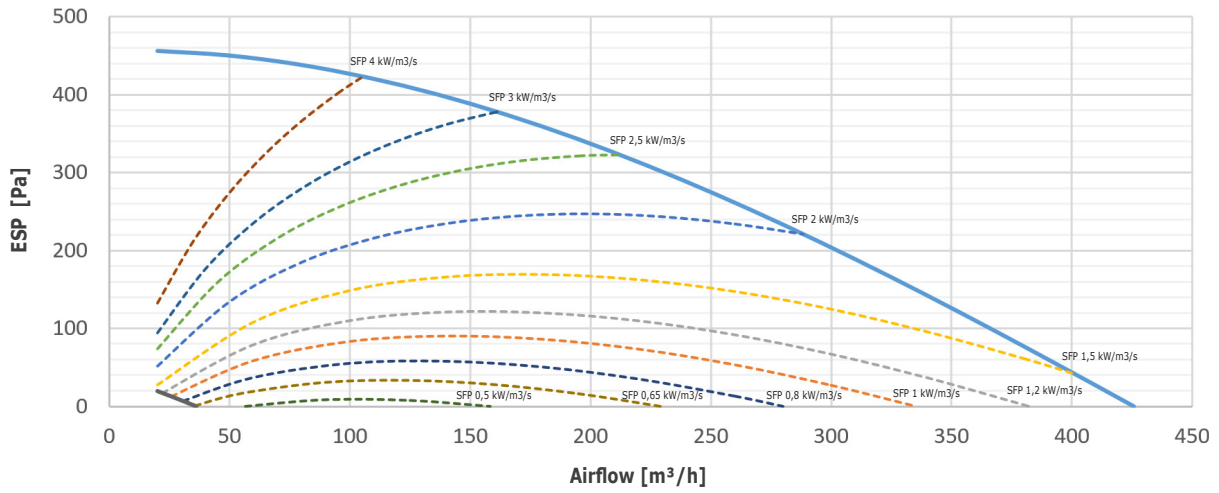

HRDF1-050

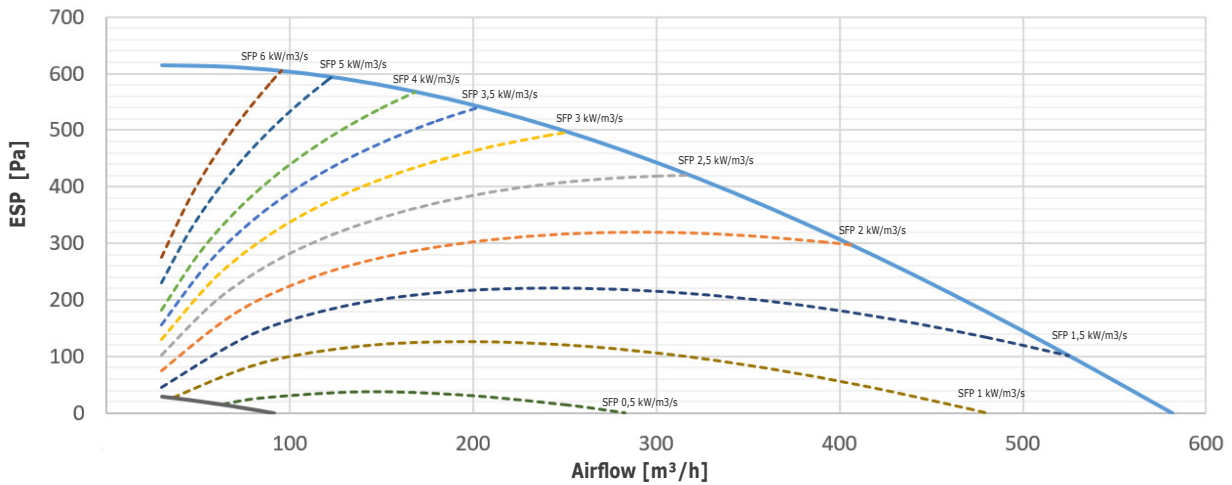

HRDF1-070

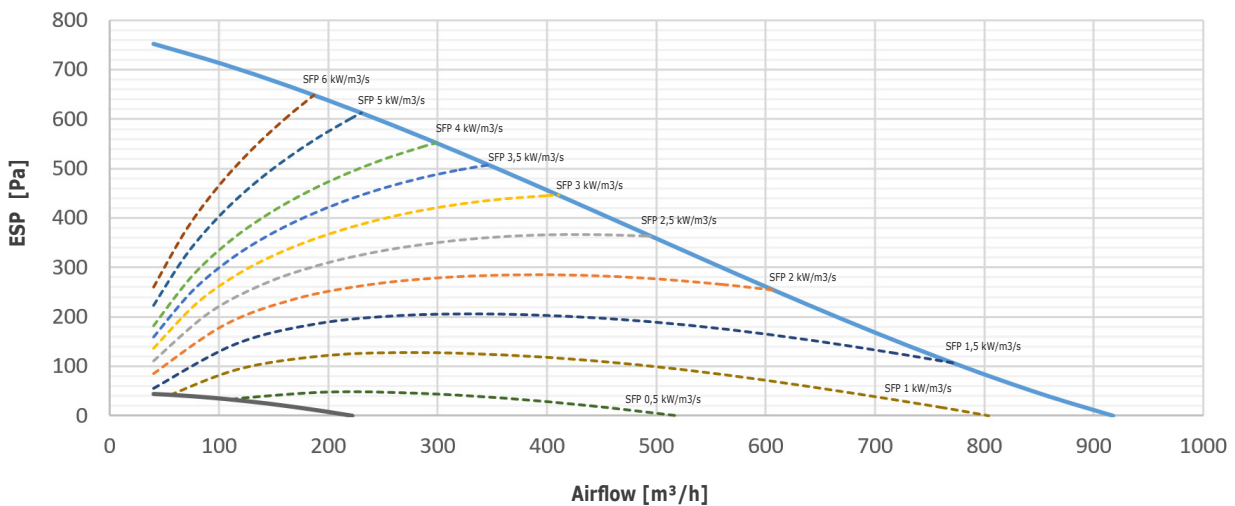

Basic technical parameters:

Type	Air flow [m³/h]	Phase [No.]	Voltage [V]	Frequency [Hz]	Max. fans power [W]	Power input of preheater [kW]	Power input of afterheater [kW]	Total current [A]	Weight [kg]
HRDF1-030-...-XS	300	1	230	50/60	100	-	-	2,0	62
HRDF1-030-...-ES	300	1	230	50/60	100	1,2	-	7,2	64
HRDF1-030-...-EE	300	1	230	50/60	100	1,2	1,2	12,4	66
HRDF1-050-...-XS	500	1	230	50/60	100	-	-	2	70
HRDF1-050-...-ES	500	1	230	50/60	100	2	-	10,7	72
HRDF1-050-...-EE	500	1	230	50/60	100	2	0,8	14,2	74
HRDF1-070-...-XS	700	1	230	50/60	200	-	-	2,6	110
HRDF1-070-...-ES	700	1	230	50/60	200	2,4	-	13,0	112
HRDF1-070-...-EE	700	3	400	50/60	200	2,4	1,2	10,4	114

Noise specifications:

HRDF1-030

Type	Airflow [m³/h]	Pressure [Pa]	Sound power level per frequency band L _{WA} (dB(A))								Overall	
			63Hz	125Hz	250Hz	500Hz	1kHz	2kHz	4kHz	8kHz	L _{WA} [dB]	L _{PA} [dB] at 3m ¹⁾
HRDF1-030	100	100	50,1	53,3	48,3	47,8	39,4	36,1	29,2	25,6	47,7	26,3
	200		49,4	53,4	51,2	49,9	42,4	39,7	32,5	27	50,1	28,7
	300		51,7	53,8	55,2	53,4	45,9	43,7	35,3	28,4	53,6	32,2

Ducts	Airflow [m³/h]	Pressure [Pa]	Sound power level per frequency band L _{WA} (dB(A))								Overall
			63Hz	125Hz	250Hz	500Hz	1kHz	2kHz	4kHz	8kHz	L _{WA} [dB]
EHA	200	100	74,8	69,2	65,9	59,8	56,2	56,4	47,9	37,1	63,7
SUP			74,6	69,1	65,7	59,6	56	56,2	47,7	36,8	63,5
ETA			69,4	61,4	55,7	45,4	34,8	28,8	20,3	14,5	51
ODA			69,2	61,3	55,6	45,2	34,7	28,6	20	14,3	50,9

1) Sound pressure levels calculated at 3 meters for Q=2

HRDF1-050

Type	Airflow [m³/h]	Pressure [Pa]	Sound power level per frequency band L _{WA} (dB(A))								Overall	
			63Hz	125Hz	250Hz	500Hz	1kHz	2kHz	4kHz	8kHz	L _{WA} [dB]	L _{PA} [dB] at 3m ¹⁾
HRDF1-050	200	150	48,2	51,9	51,9	48,9	41	39,6	33,9	28,9	49,6	28
	300		51,3	54	54,5	50,6	43,8	42,4	36,3	32,7	51,9	30,3
	400		55,2	57,5	57,9	52,6	46,9	45,5	39,6	37,5	54,8	33,1
	500		58,7	59,8	63,2	56,2	49,9	48,4	42,8	39,9	58,7	37

Ducts	Airflow [m³/h]	Pressure [Pa]	Sound power level per frequency band L _{WA} (dB(A))								Overall
			63Hz	125Hz	250Hz	500Hz	1kHz	2kHz	4kHz	8kHz	L _{WA} [dB]
EHA	300	150	70,4	66,4	65,2	59,3	55,9	56,3	49,5	44,5	63,2
SUP			70,3	66,3	65,2	59,1	55,7	56,2	49,4	44,4	63,1
ETA			69,1	66,1	54,7	45,5	38,9	35,2	26,2	20,7	52,8
ODA			69	65,9	54,6	45,3	38,8	35	26	20,6	52,6

1) Sound pressure levels calculated at 3 meter for Q=2



HRDF1-070

Type	Airflow [m³/h]	Pressure [Pa]	Sound power level per frequency band L _{WA} (dB(A))								Overall	
			63Hz	125Hz	250Hz	500Hz	1kHz	2kHz	4kHz	8kHz	L _{WA} [dB]	L _{PA} [dB] at 3m 1)
HRDF1-070	300	150	56,4	59,5	51,1	48,5	45,2	42,5	30,3	28,6	51,2	29,4
	400		56,4	59,5	53,2	49,7	46,2	43,9	31,4	32,9	52,4	30,6
	500		56,9	60	55,5	51,4	47,6	45,5	33,1	37	54	32,2
	600		58,4	61,2	57,7	53,5	49,4	47,3	35,5	40,4	55,9	34,1
	700		61,4	63,5	59,2	55,7	51,4	49,1	38,9	42,5	57,9	36,1

Ducts	Airflow [m³/h]	Pressure [Pa]	Sound power level per frequency band L _{WA} (dB(A))								Overall
			63Hz	125Hz	250Hz	500Hz	1kHz	2kHz	4kHz	8kHz	L _{WA} [dB]
EHA	500	150	74	71,4	68,6	61	57,5	58	48,3	51,5	65,5
SUP			74,4	71,7	68,9	61,4	57,9	58,5	48,9	52,2	66
ETA			69,8	68,4	59,9	44,8	39,3	33,9	23,8	23,8	55,5
ODA			70,3	68,9	60,1	45,2	39,7	34,4	24,4	24,3	55,9

1) Sound pressure levels calculated at 3 meters for Q=2

DIMENSIONS

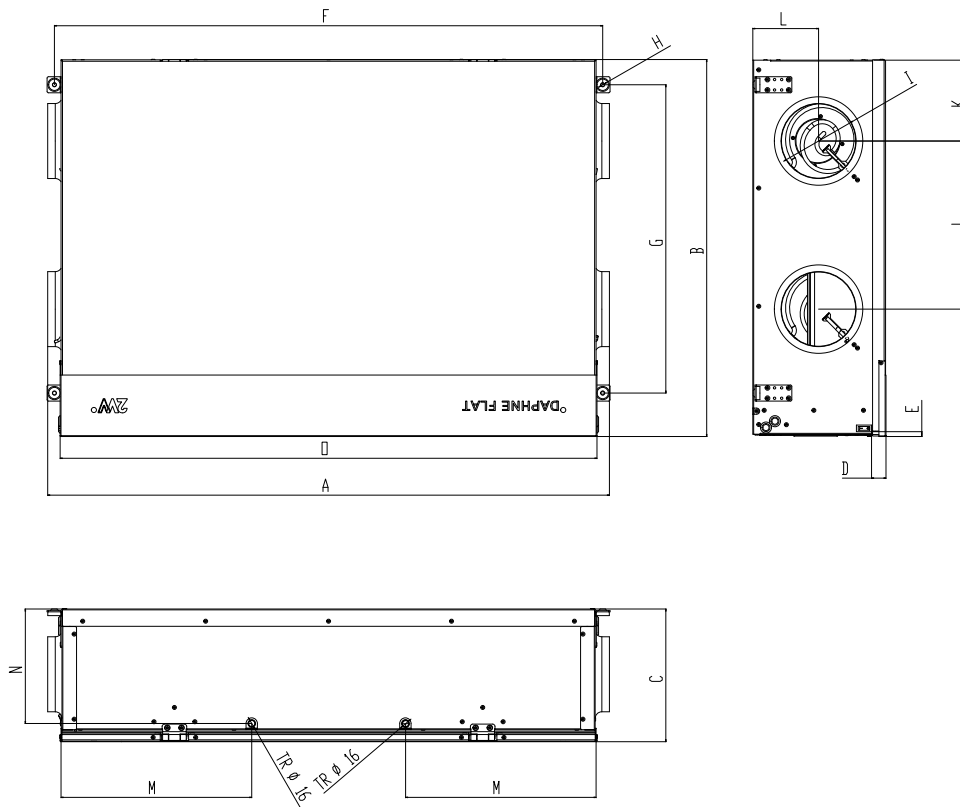

Type	[mm]														
	A	O	B	C	D	E	F	G	H	I	J	K	L	M	N
HRDF1-030	1188	1135	797	281	30	10	1160	652	Ø8	Ø160	355	171	139	403	242
HRDF1-050	1432	1347	885	322	30	10	1380	702	Ø8	Ø200	400	195	157	517	285
HRDF1-070	1646	1547	1065	364	30	10	1580	902	Ø8	Ø250	508	228	180	619	326



INSTALLATION AND ASSEMBLY

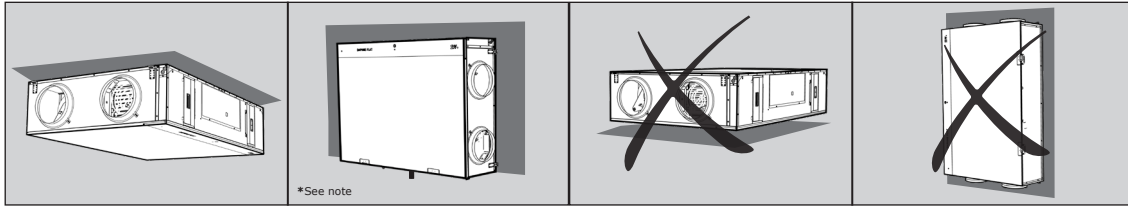

- * Installation on the wall possible only for HRDF1-030
- * Installing HRDF1-030 on the wall is possible only when the position of the condensate drain points downwards

The unit can be suspended using threaded rods (M8) from the ceiling or wall. The unit must be installed with a respect to a correct position of the condensate drain.

The installation of the unit must allow sufficient access for maintenance, service and disassembling operations.

Necessary service access distances

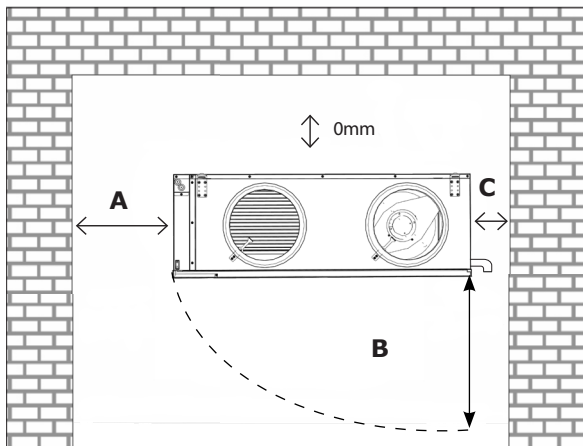

	A	B	C
HRDF1-030	min. 450mm	min. 850mm	min. 150mm
HRDF1-050	min. 500mm	min. 950mm	min. 150mm
HRDF1-070	min. 600mm	min. 1150mm	min. 150mm

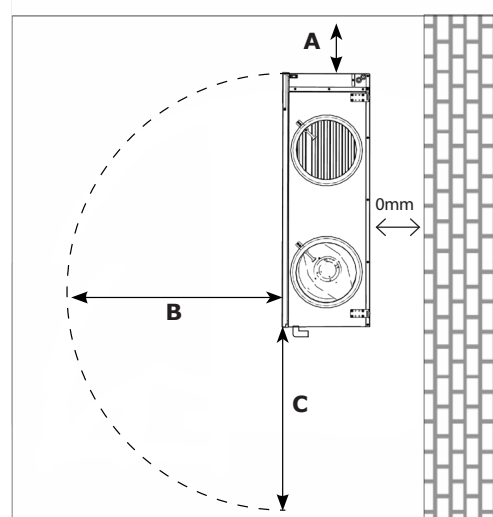

	A	B	C
HRDF1-030	min. 450mm	min. 850mm	min. 850mm
HRDF1-050	not possible	not possible	not possible
HRDF1-070	not possible	not possible	not possible

- The unit must be securely fastened to prevent it from falling.
- The air ducting is connected by sliding it over the circular air spigots.



CONTROL

AirGENIO COMFORT - Main control functions

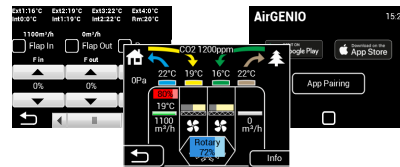
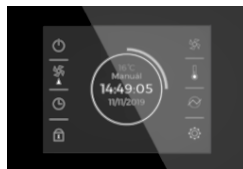
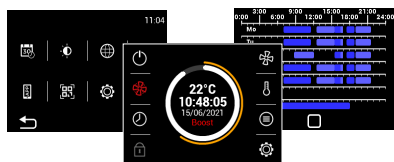

- Touch control
- Stepless fans (0-10V)
- Stepless afterheating (internal electrical: SSR)
- Stepless automatic control of preheating
- Integrated timer (daily, weekly)
- Optional connection of sensors: CO2, RH, VOC (0-10)
- Stepless Bypass (temperature control: freecooling, antifreeze protection)
- Offset fan adjustment (over-pressure and underpressure)
- Indication of filter clogging
- CAV or DCV ventilation mode
- BOOST function - intensive airflow for a set period
- Freecooling functions - night ventilation (cooling)
- Occupancy functions - reducing ventilation according to the PIR sensor
- BMS - connection via Modbus RTU / TCP, BACnet

2VV AirGENIO Application:

- Product control on your smartphone
- Info about operation status
- Notifications – request for service, filter exchange, error status, etc.
- Download the 2VV AirGENIO APP and control it remotely from your smart phone!



2VV Service software:

- Easy and quick commissioning from your computer
- Error log – error display and identification
- Easy service (device status loading/reset to backup setting)
- Fast FW update
- OFFLINE version





AirGENIO Comfort connection

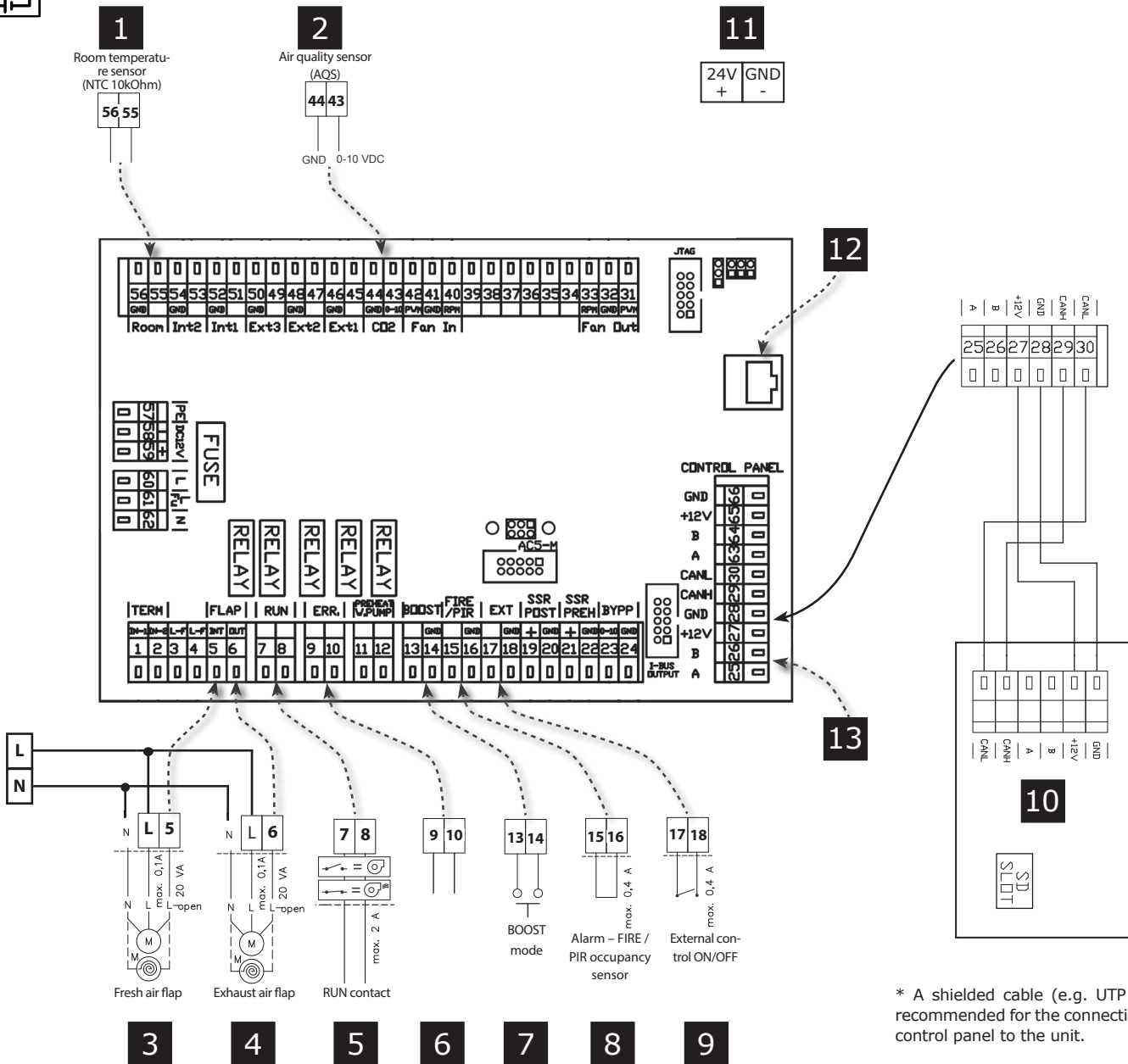

* A shielded cable (e.g. UTP type) is recommended for the connection of the control panel to the unit.

1	Room temperature sensor (input)
2	The air quality sensor - control signal (input)
3	Inlet air damper (L-in)
4	Exhaust air damper (L-out)
5	RUN contact (relay contact)
6	ERROR contact (relay contact)
7	BOOST regime (input)
8	Alarm - FIRE (input) or PIR (input)
9	External control - ON/OFF
10	Control panel
11	24V power supply
12	RJ45 plug - Ethernet, Modbus TCP, BACnet
13	Modbus RTU (A-25, B-26, 28 or 66-GND)



ACCESSORIES

RECOMMENDED ACCESSORIES



Distribution box
ROZ-EPP-125

The distributor/collector is a distribution box designed for the distribution of air. It helps to divide air in to up to 8 distribution/collection ducts. It provides a solution for the connection between flexible air ducts (e.g. Isovac, Sonovac, Semivac and Aluv DN 125) and Duotec flexible hoses. The distributor/collector can be connected to up to 8 Duotec flexible hoses. The flexible hoses are attached by insertion. To ensure the correct position of the flexible hoses it is necessary to insert the hose into the box until it clicks in. The distributor /collector is intended for operation in standard indoor areas for the distribution/collector of clean air without coarse dust, fats, chemical vapours and other pollutants with a temperature of up to 40°C.

Material: The distributor/collector is produced from black-coloured extruded polypropylene and is not load bearing.

The package includes: Box (inlet with a connection diameter of 125mm), four removable plugs.

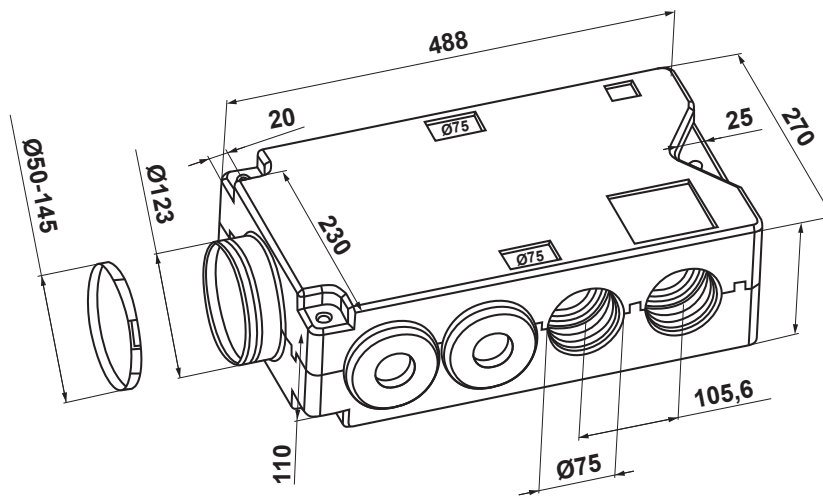



INSTALLATION AND ASSEMBLY

The box can be suspended under a ceiling using three threaded rods or installed into the floor (a layer for spreading the load is necessary).

Ceiling installation

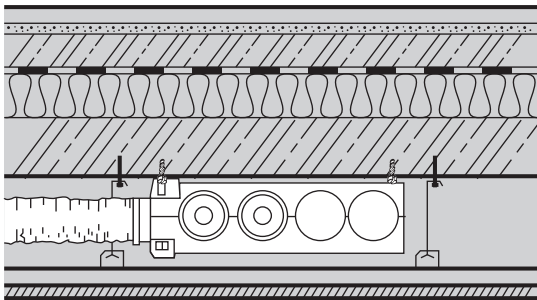

Floor installation

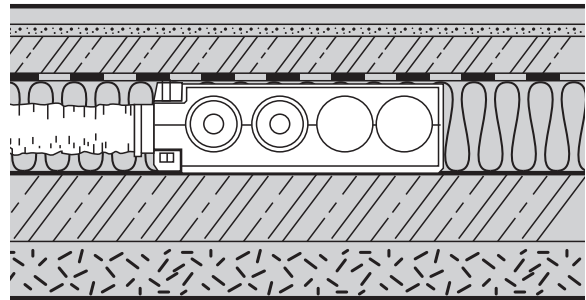

Example of installation

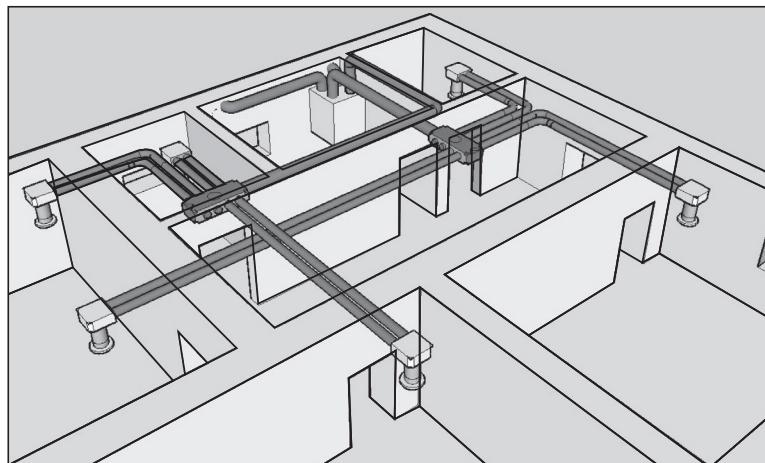

KEY TO CODING

ROZ-EPP-125

125 - Connection diameter 125mm

ROZ-EPP - Universal distribution, EPP, 8 outlets



ACCESSORIES

RECOMMENDED ACCESSORIES

Flexible hose
ROZ-DUOTEC075/063



The Duotec flexible hose is intended for the delivery and exhaust of air free of coarse dust, fats, chemical vapours and other pollutants. The hose is suitable for use in ventilation systems with a heat recovery unit. It is recommended that installation is performed at temperatures above 0°C! The recommended air flow rate through the hose is 15-30 m³/h.

Material: The material used is environmentally friendly. PE is resistant to practically all agents (alcohol, fats, mineral oils, fuels). Only highly concentrated oxidising acids can damage the PE. 450N pressure test. The duct dimensions correspond to the requirements of DIN EN 50086-24.

The package includes: 50 m roll with two plugs and one coupling.

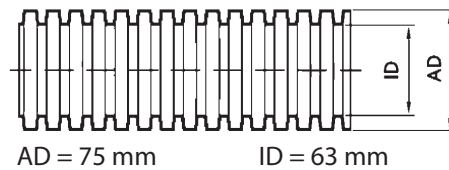

Pressure loss per 1m of hose length

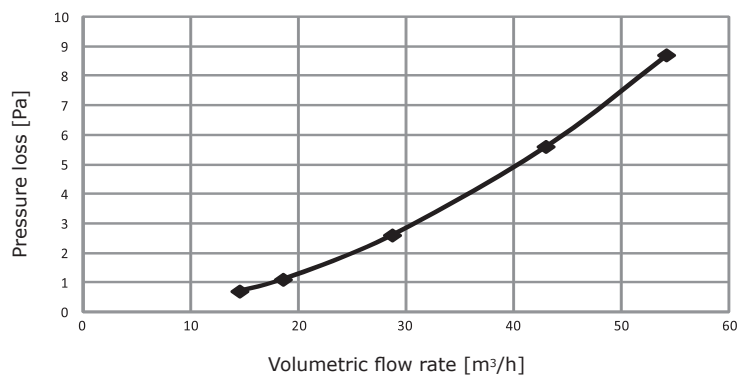

KEY TO CODING

ROZ-DUOTEC075/063

ROZ-DUOTEC 075/063 – Duotec PE flexible hose, diameter 075/063mm, length 50m



ACCESSORIES

RECOMMENDED ACCESSORIES

Spatial sensor CO2: CI-CO2-R

Sensor combines CO2. The snap-in mounting concept stands for easy installation.



Spatial sensor RH: CI-RH-R

Capacitive relative humidity sensor with 0-10V analog and relay output.



CI-AQS-COMBI

is a signal combiner for AQS sensors using 0-10V logic which you can connect up to 10 different sensors. The input signal with the highest voltage will be the signal that is on the output terminal.



CT-ROOM

Temperature sensor for air temperature measurement in a reference room.



Shutting flap

KRTK-A

Shutting flap for tight closing of inlet branch when unit is not in use.



Type of unit	Flap type
HRDF1-030	KRTK-A160
HRDF1-050	KRTK-A200
HRDF1-070	KRTK-A250

Shutting flap with servo drive

KRTK-A-SB

Shutting flap for tight closing of inlet branch when unit is not in use.



Type of unit	Flap type
HRDF1-030	KRTK-A-160-SB
HRDF1-050	KRTK-A-200-SB
HRDF1-070	KRTK-A-250-SB



Servodrive

SERVO-LM230-05

Necessary accessory for automatic control of the closing flap.



OPTIONAL ACCESSORIES

More details can be found on the relevant page in this catalog

Spare air filters

Filter replacements of different classes and configurations.



Type of unit	Supply air filter			Exhaust air filter
	COARSE 60% (G4)	COARSE 90% (M5)	ePM 1 60% (F7)	COARSE 60% (G4)
HRDF1-030	HRDF1-030-FI-G4	HRDF1-030-FI-M5	HRDF1-030-FI-F7	HRDF1-030-FI-G4
HRDF1-050	HRDF1-050-FI-G4	HRDF1-050-FI-M5	HRDF1-050-FI-F7	HRDF1-050-FI-G4
HRDF1-070	HRDF1-070-FI-G4	HRDF1-070-FI-M5	HRDF1-070-FI-F7	HRDF1-070-FI-G4

Connection sleeve

MK

Connection sleeve for easier removal of unit when servicing and for elimination of vibrations in duct.

Type of unit	Connection sleeve
HRDF1-030	MK160
HRDF1-050	MK200
HRDF1-070	MK250



Round silencer

SPTGLX

Type of unit	Round silencer
HRDF1-030	SPTGLX-1,0-160
HRDF1-050	SPTGLX-1,0-200
HRDF1-070	SPTGLX-1,0-250



Threaded rods

ZTZ-M8-1,0 – threaded rod, thread M8, length 1m, suitable for all types of under the ceiling type units.

**Siphon for condensate****SK-HL138**

Siphon with a ball for installation on the wall or flush mounting.

**Back draught shutter****RSKR-Z**

Type	Shutter
HRDF1-030	RSKR-Z160
HRDF1-050	RSKR-Z200
HRDF1-070	RSKR-Z250





KEY TO CODING

HRDF1-030 H P CB E 44 - E E1 C- 0 A0

