



Counterflow plate heat recovery exchanger



Enthalpy counterflow heat recovery exchanger



## BASIC FEATURES

**ALFA 95-3 UPPER** – heat recovery ventilation unit range with top connections, designed for commercial and retail constructions such as **offices, shops, restaurants, hotels, sport centres, public premises**, etc.

- **4 sizes** with nominal airflow **1500m<sup>3</sup>/h** @250Pa - **4700m<sup>3</sup>/h** @320Pa
- **Low SPI** at nominal airflow
- **Low sound** parameters
- **Fits through a 900mm wide door**
- Counterflow desk-plate heat exchanger – **aluminium or enthalpy**
- Integrated **AirGENIO control system**
- Ecodesign directive 1253/2014 compliant

ALFA 95-3 UPPER is with frameless self-supporting construction designed to fit through a 900mm wide door. Sizes 150 and 220 are monoblocs, sizes 320 and 470 are modular equipped with connecting elements and connectors. Casing is made from double skin mineral wool insulation panels of 50mm thickness with powder coating in RAL9010 and RAL9005. The supply and extract of the unit is equipped with energy efficient centrifugal fans. The unit is fitted with counterflow desk-plate heat recovery system – aluminium or enthalpy core, which are EUROVENT certified. The heat recovery system has an integrated by-pass damper with servo drive.

The unit is fitted with air filters (pre-filter Coarse 60%, supply ePM1 60%, extract ePM10 50%) that are monitored by pressure transmitters. Upon request the unit is equipped with heating / cooling – electric, water, WCO, DX.

Complete control system AirGENIO is integrated and factory installed, together with its touch screen control panel and communication UTP cable.

ALFA 95-3 UPPER heat recovery unit is designed to be operated at an indoor environment and at an ambient temperature in the range from -20°C up to +60°C, for transporting standard atmospheric air that is free of dust, grease, chemical emissions and other impurities. The unit, when installed in the ducting system has an IP rating of IP43. The design of the ventilation project must be **always designed by a qualified HVAC designer, engineer or architect.**

Functional diagram

Operational diagram right version upper connections

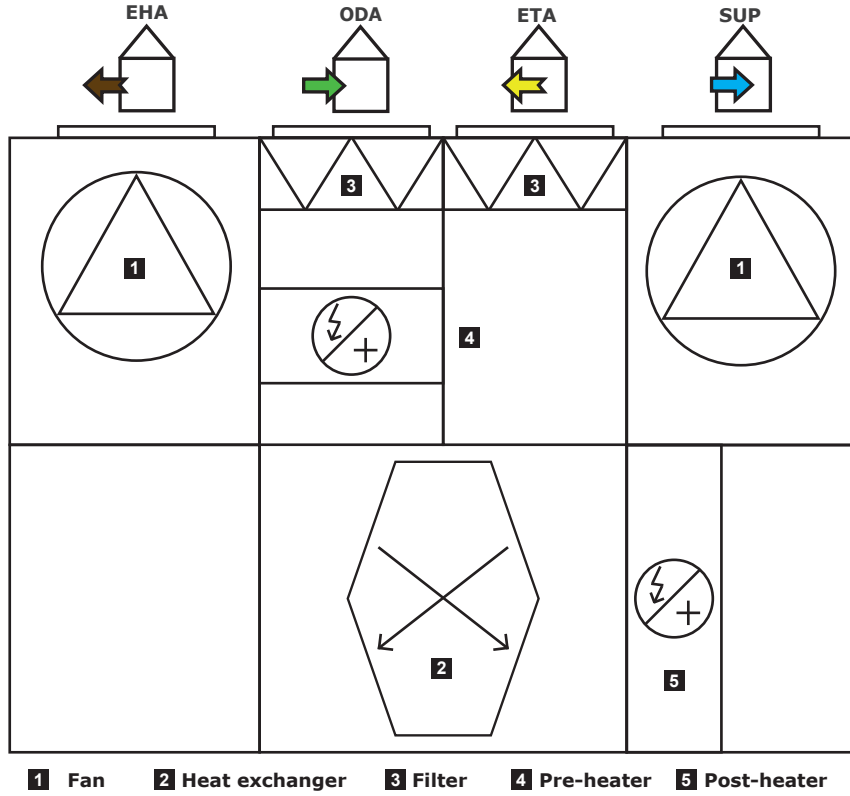

Operational diagram left version upper connections

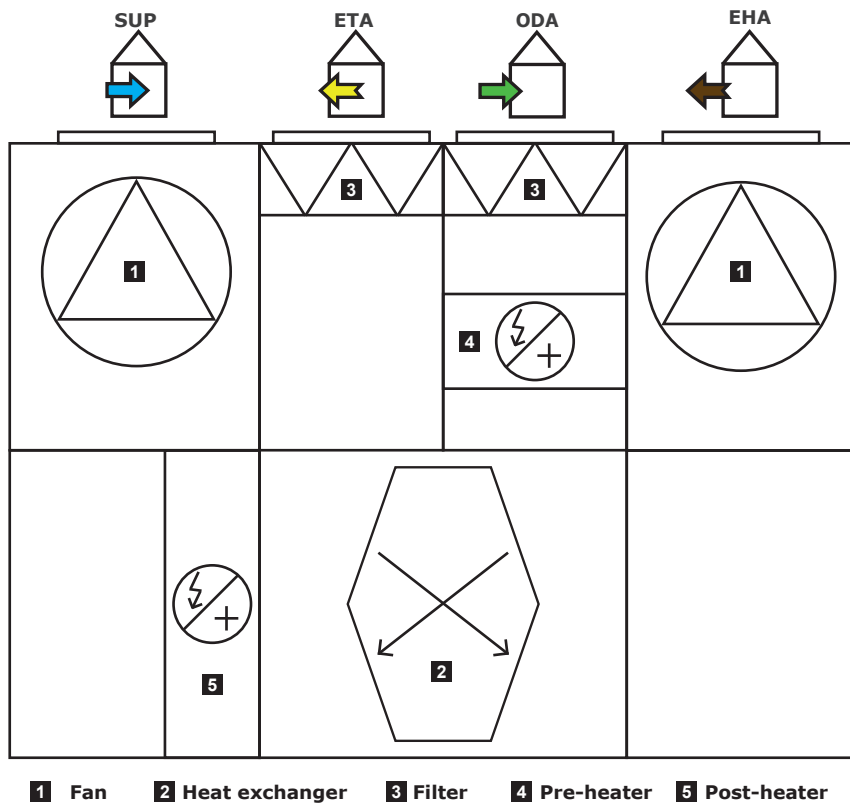



**PRIMARY PARAMETERS**

Heat recovery efficiency standart heat recovery exchanger - CB:  
EN308-W1 (Tout - 5°C/72%RH, Tin - 25°C/28%RH)

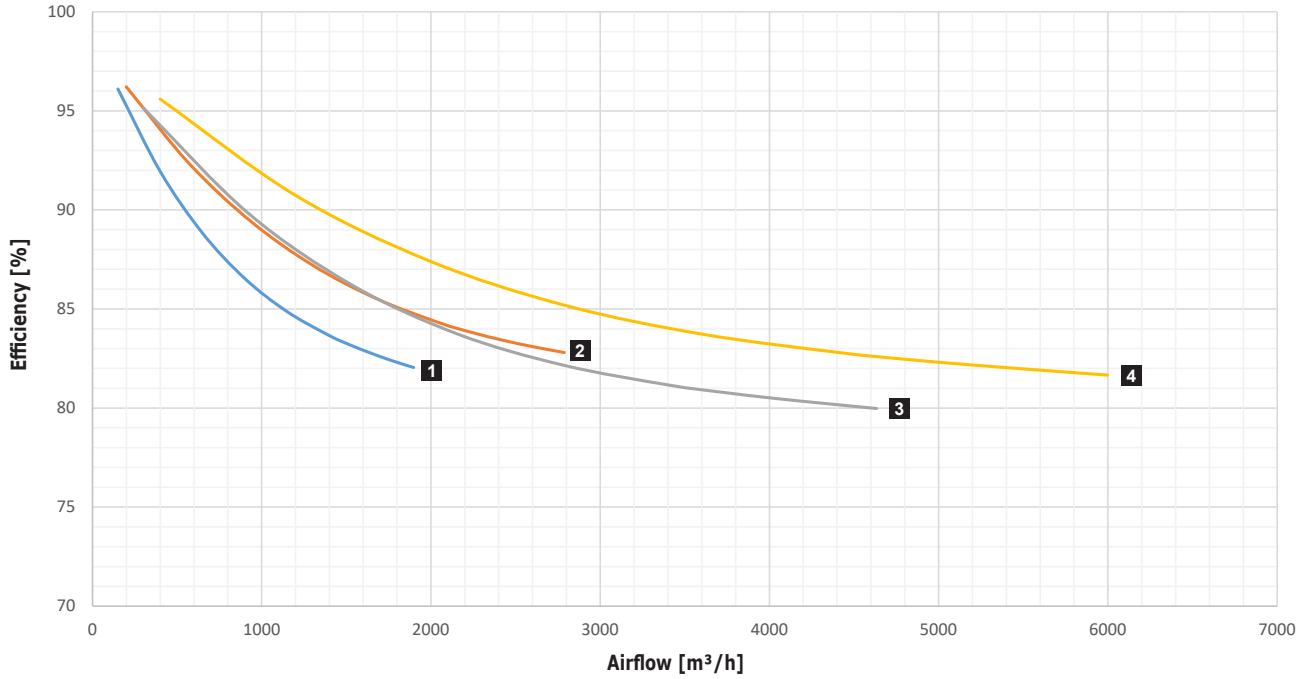

**1** HR953-150U CB    **2** HR953-220U CB    **3** HR953-320U CB    **4** HR953-470U CB

Heat recovery efficiency enthalpy heat recovery exchanger - EB:  
EN308-W1 (Tout - 5°C/72%RH, Tin - 25°C/28%RH)

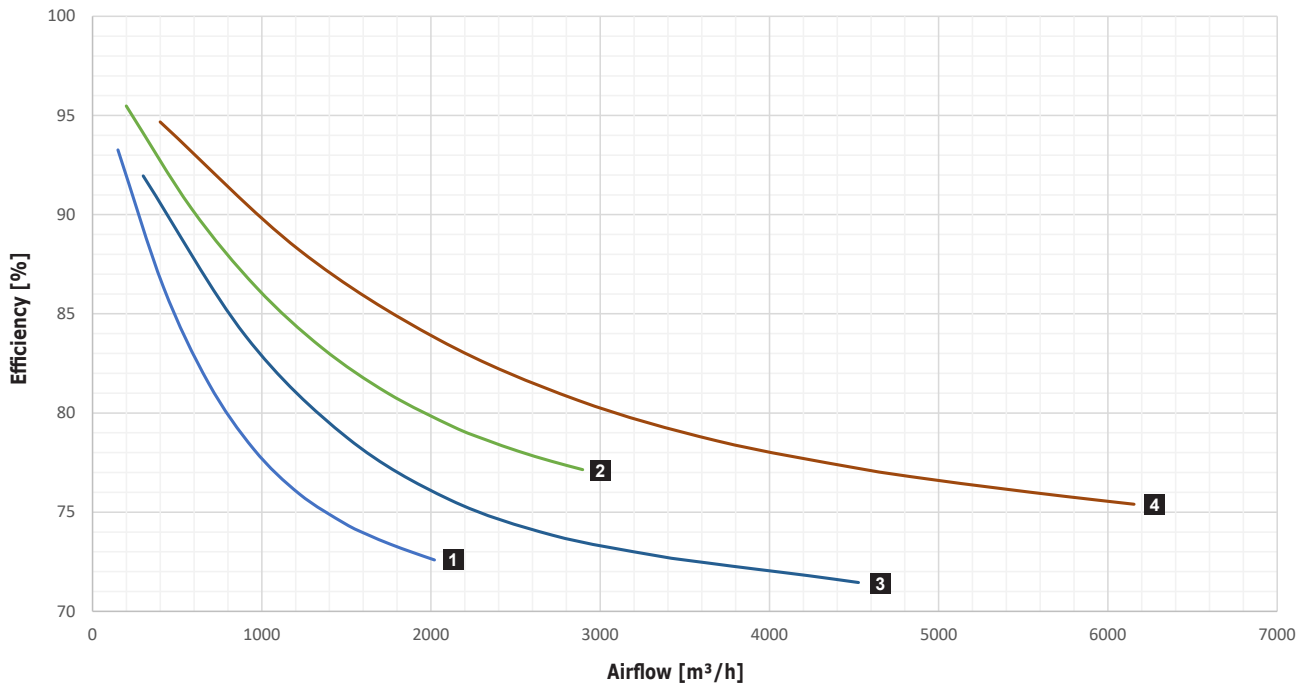

**1** HR953-150U EB    **2** HR953-220U EB    **3** HR953-320U EB    **4** HR953-470U EB

**PRIMARY PARAMETERS**

**HR953-150 U CB**

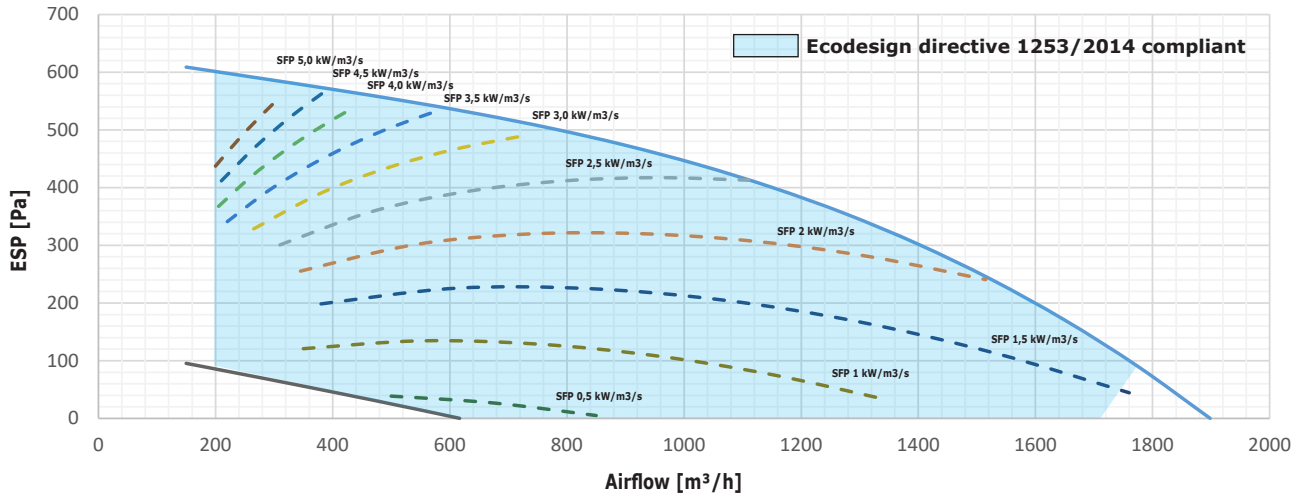

**HR953-220 U CB**

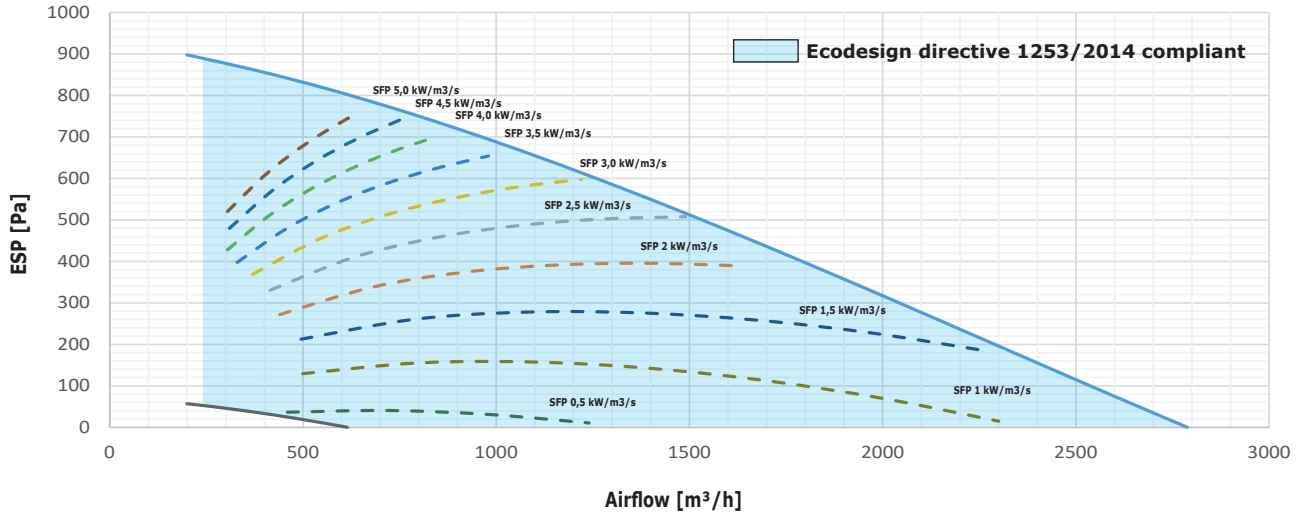



PRIMARY PARAMETERS

HR953-320 U CB

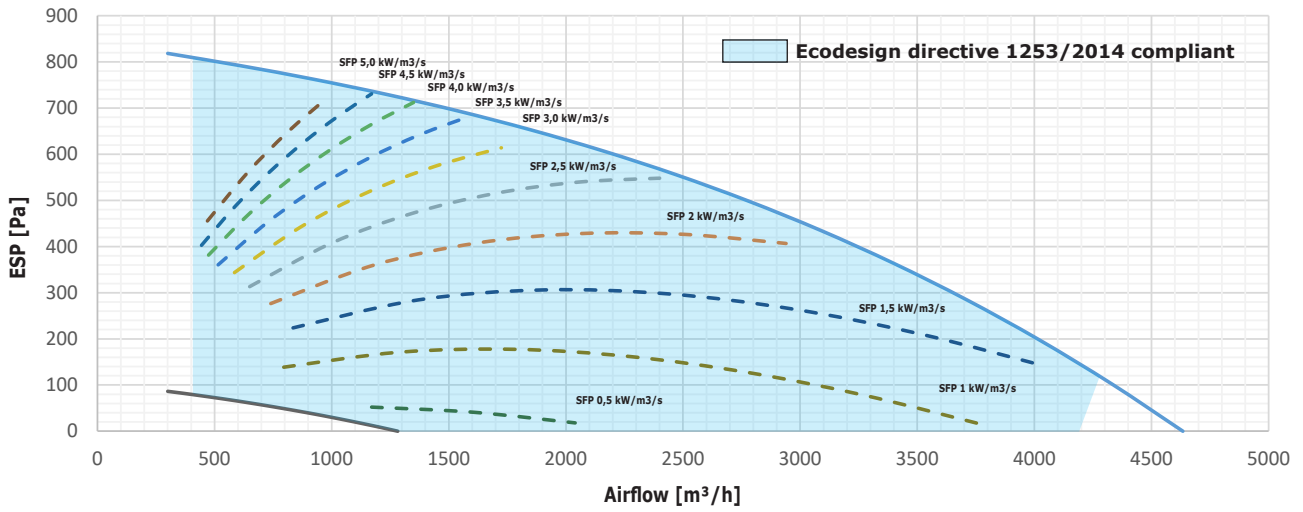

HR953-470 U CB

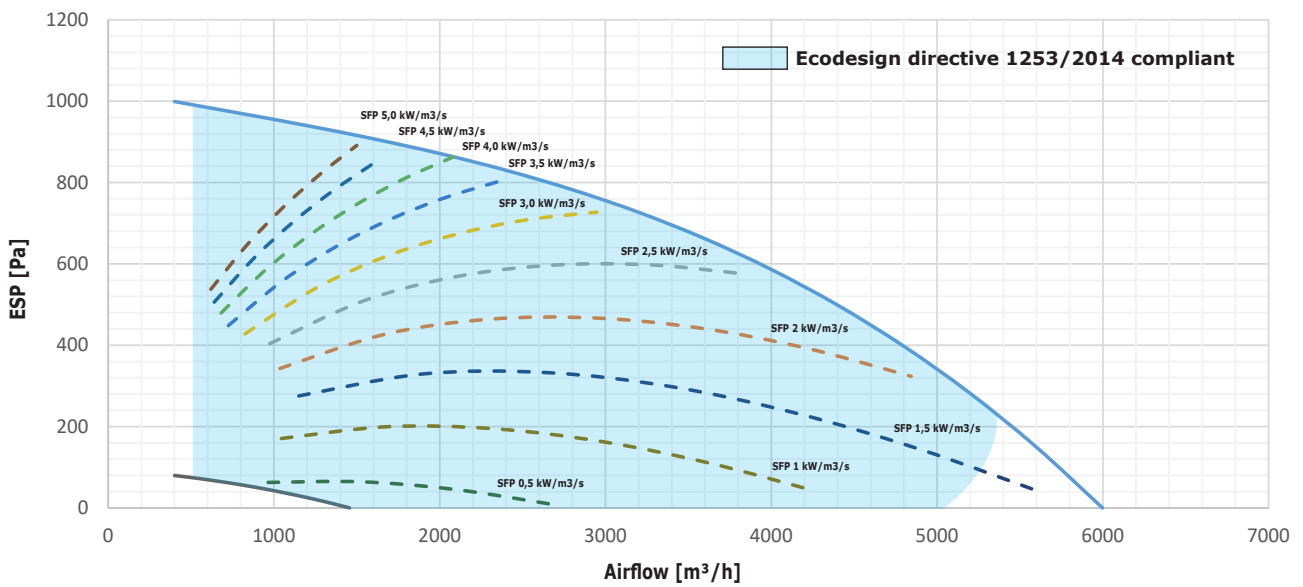

**PRIMARY PARAMETERS**

**HR953-150 U EB**

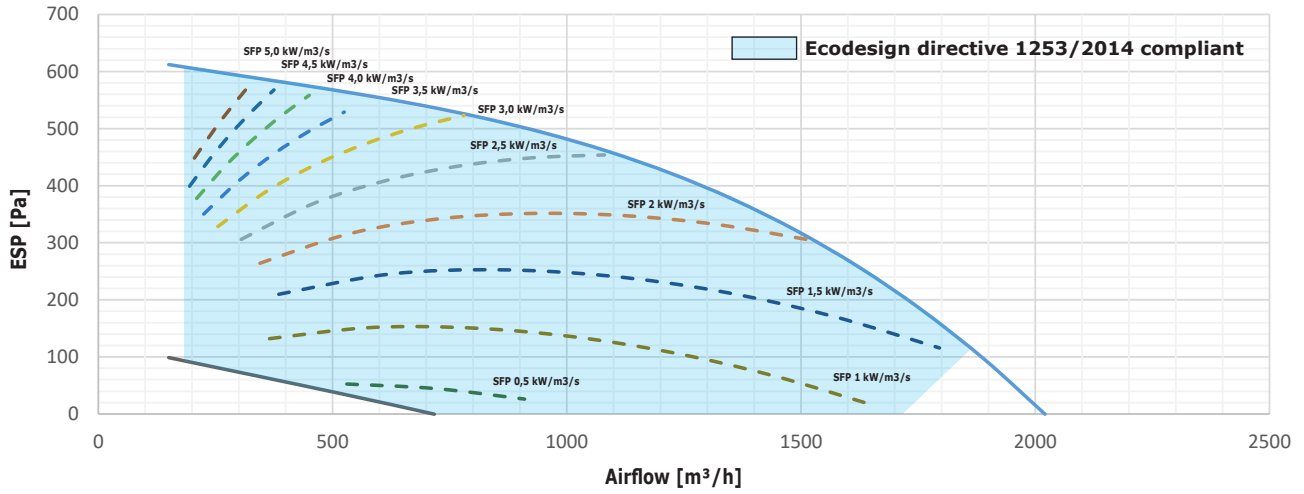

**HR953-220 U EB**

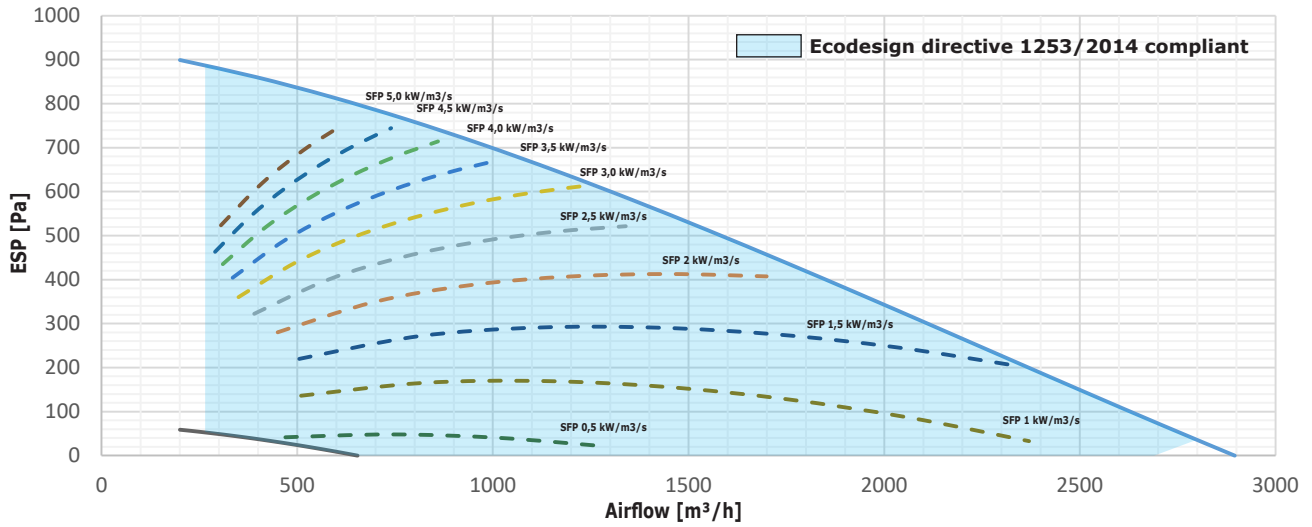



PRIMARY PARAMETERS

HR953-320 U EB

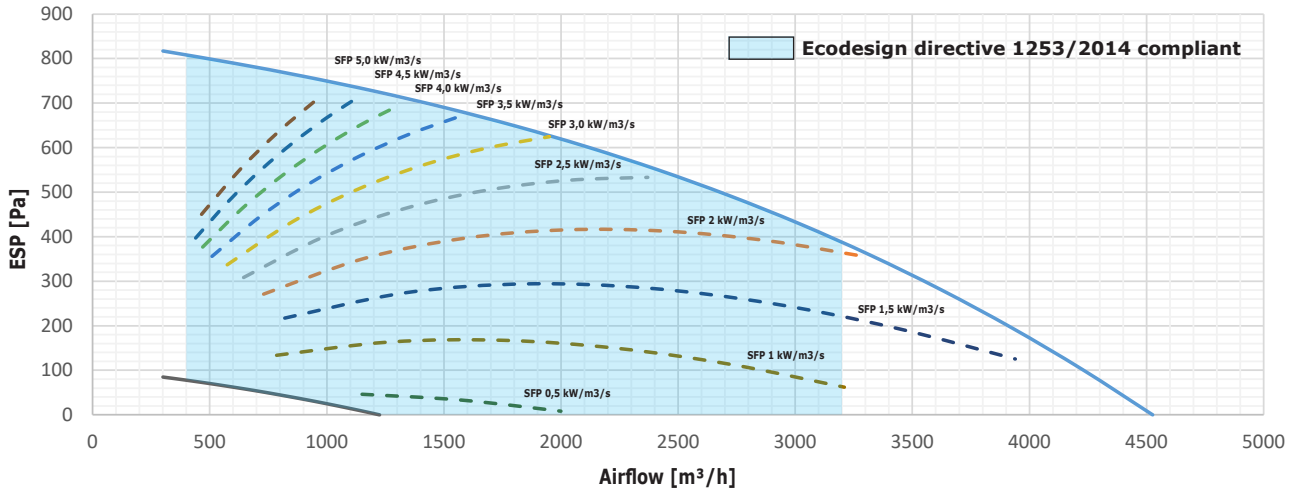

HR953-470 U EB

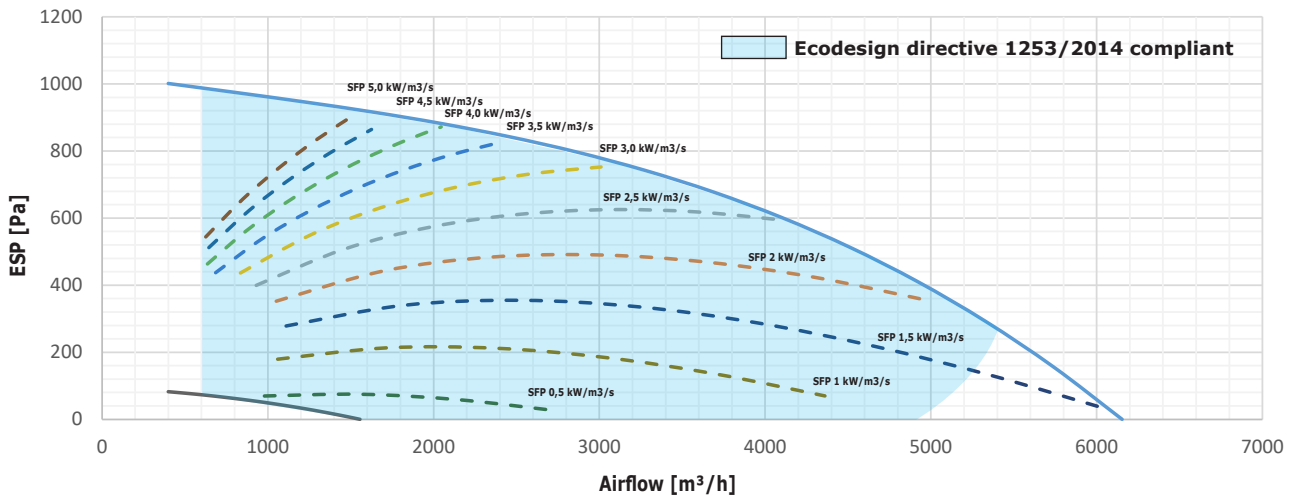



### Noise specifications:

HR95-150U

Airflow [m³/h]	Pressure [Pa]	Sound power level per frequency band								Overall	
		63Hz	125Hz	250Hz	500Hz	1kHz	2kHz	4kHz	8kHz	L <sub>WA</sub> [dB]	L <sub>PA</sub> [dB] at 3m
500	100	60,6	55,4	43,8	38,3	36,2	32,5	30,2	23,8	44,1	<b>21,5</b>
900		60,8	56,1	47,3	41,4	39,2	36,2	31,4	24,9	46,3	<b>23,6</b>
1300		64,1	59,2	52,7	45,8	43,1	41,0	34,6	28	50,5	<b>27,8</b>
1500		66,1	61,3	55,3	47,8	45,2	43,3	36,5	29,8	52,7	<b>30,0</b>

Branch	Airflow [m³/h]	Pressure [Pa]	Sound power level per frequency band								Overall
			63Hz	125Hz	250Hz	500Hz	1kHz	2kHz	4kHz	8kHz	L <sub>WA</sub> [dB]
EHA	900	100	68,8	69,3	62,5	56,5	54,9	52,2	44,7	47,3	<b>61,1</b>
SUP			71,4	67,9	61,7	58,8	60,7	57,3	48,4	48,7	<b>64,4</b>
ETA			62,8	58,4	52,2	47,4	44,0	36,9	29,8	24,5	<b>50,2</b>
ODA			63,4	58,8	50,6	45,5	42,2	37,4	28,3	19,4	<b>49,1</b>

HR95-220U

Airflow [m³/h]	Pressure [Pa]	Sound power level per frequency band								Overall	
		63Hz	125Hz	250Hz	500Hz	1kHz	2kHz	4kHz	8kHz	L <sub>WA</sub> [dB]	L <sub>PA</sub> [dB] at 3m
600	150	62,0	59,4	45,8	38,7	36,3	32,8	25,6	18,5	46,2	<b>23,2</b>
1500		56,6	55,6	52,2	44,3	42,2	38,4	32,9	22,2	48,7	<b>25,8</b>
1800		58,0	54,6	57,4	47,1	44,3	40,7	35,7	25,1	51,9	<b>29,0</b>
2200		61,3	54,9	60,4	50,0	47,1	43,9	39,4	28,8	54,8	<b>31,9</b>

Branch	Airflow [m³/h]	Pressure [Pa]	Sound power level per frequency band								Overall
			63Hz	125Hz	250Hz	500Hz	1kHz	2kHz	4kHz	8kHz	L <sub>WA</sub> [dB]
EHA	1800	150	63,9	64,9	66,1	59,0	58,0	53,9	50,6	46,0	<b>63,3</b>
SUP			63,9	64,7	65,5	62,1	63,1	58,7	54,5	50,3	<b>66,8</b>
ETA			62,4	56,8	57,3	48,8	43,1	40,0	34,7	25,9	<b>52,2</b>
ODA			65,5	57,7	57,1	47,8	41,8	38,6	27,5	18,1	<b>51,7</b>



**Noise specifications:**

HR95-320U

Airflow [m <sup>3</sup> /h]	Pressure [Pa]	Sound power level per frequency band								Overall	
		63Hz	125Hz	250Hz	500Hz	1kHz	2kHz	4kHz	8kHz	L <sub>WA</sub> [dB]	L <sub>PA</sub> [dB] at 3m
800	150	72,5	59,0	47,4	39,7	37,4	32,8	25,8	23,2	49,2	<b>25,8</b>
1400		66,2	60,4	48,8	40,6	38,7	33,9	27,2	21,6	48,1	<b>24,8</b>
2600		64,3	64,3	49,3	45,4	43,4	39,5	31,9	24,0	51,3	<b>28,0</b>
3200		66,0	65,7	51,7	48,8	46,4	43,2	35,3	27,7	53,7	<b>30,3</b>

Branch	Airflow [m <sup>3</sup> /h]	Pressure [Pa]	Sound power level per frequency band								Overall
			63Hz	125Hz	250Hz	500Hz	1kHz	2kHz	4kHz	8kHz	L <sub>WA</sub> [dB]
EHA	2600	150	75,1	74,4	63,1	58,2	56,5	52,0	45,8	38,1	<b>63,2</b>
SUP			76,6	76,1	62,8	61,4	59,9	55,7	48,0	41,1	<b>65,6</b>
ETA			69,0	63,0	52,7	49,4	45,1	37,8	31,5	25,8	<b>52,5</b>
ODA			66,8	61,8	51,1	48,1	44,0	34,8	25,2	18,5	<b>51,0</b>

HR95-470U

Airflow [m <sup>3</sup> /h]	Pressure [Pa]	Sound power level per frequency band								Overall	
		63Hz	125Hz	250Hz	500Hz	1kHz	2kHz	4kHz	8kHz	L <sub>WA</sub> [dB]	L <sub>PA</sub> [dB] at 3m
1000	200	71,5	64,2	47,7	43,3	42,7	39,1	33,2	26,3	51,7	<b>28,4</b>
2000		65,9	65,2	48,6	44,9	44,8	41,1	34,7	26,9	52,2	<b>28,8</b>
3500		68,2	67	52,6	50,3	50,0	45,9	38,5	28,2	55,7	<b>32,4</b>
4500		68,8	66,3	58,0	54,9	53,6	49,6	41,8	30,2	58,6	<b>35,2</b>

Branch	Airflow [m <sup>3</sup> /h]	Pressure [Pa]	Sound power level per frequency band								Overall
			63Hz	125Hz	250Hz	500Hz	1kHz	2kHz	4kHz	8kHz	L <sub>WA</sub> [dB]
EHA	3500	200	72,1	70,8	63,7	58,3	59,8	54,9	48,8	44,1	<b>63,9</b>
SUP			72,1	70,2	63,1	60,9	63,4	59,8	53,1	48,2	<b>66,9</b>
ETA			67,0	62,1	56,0	51,6	47,9	41,2	32,4	24,3	<b>54,1</b>
ODA			66,0	60,9	55,5	52,1	48,2	41,5	31,2	19,3	<b>54,0</b>

**Basic technical parameters of the heat recovery units:**

Model without electric preheater or postheater / with water, CO or DX post heater

Model	Phase [pcs]	Voltage [V]	Frequency [Hz]	Rated input [kW]	Total current [A]
HR953-150	1	230	50/60	0,9	5,9
HR953-220	1	230	50/60	1,0	6,6
HR953-320	3	400	50/60	2,8	6,3
HR953-470	3	400	50/60	2,8	6,5

Model with electric preheater (without electric postheater)

Model	Phase [pcs]	Voltage [V]	Frequency [Hz]	Rated input [kW]	Total current [A]
HR953-150	3	400	50/60	5,9	12,5
HR953-220	3	400	50/60	8,5	17,4
HR953-320	3	400	50/60	13,5	21,8
HR953-470	3	400	50/60	18,4	29,0

Model with electric postheater only

Model	Phase [pcs]	Voltage [V]	Frequency [Hz]	Rated input [kW]	Total current [A]
HR953-150	1	230	50/60	3,4	16,8
HR953-220	3	400	50/60	4,9	9,8
HR953-320	3	400	50/60	8,2	14,1
HR953-470	3	400	50/60	11,2	18,6

Model with electric preheater and postheater

Model	Phase [pcs]	Voltage [V]	Frequency [Hz]	Rated input [kW]	Total current [A]
HR953-150	3	400	50/60	8,4	16,8
HR953-220	3	400	50/60	12,4	20,6
HR953-320	3	400	50/60	18,9	29,6
HR953-470	3	400	50/60	26,8	41,1

Characteristics of electric motors (1 fan only)

Model	Phase [pcs]	Voltage [V]	Frequency [Hz]	Rated input [W]	Total current [A]	Speed [r/min]	Protection IP	Insulation class	Weight [kg]
HR953-150	1	200-277	50/60	410	1,9	2400	54	B	4,1
HR953-220	1	200-277	50/60	500	2,3	2360	55	F	7,0
HR953-320	3	380/480	50/60	1400	2,1	2480	55	F	8,7
HR953-470	3	380/480	50/60	1400	2,3	2480	55	F	8,7

Characteristics of electric preheater

Model	Phase [pcs]	Voltage [V]	Frequency [Hz]	Rated input [kW]	Total current [A]
HR953-150	3	400	50/60	5,0	12,5
HR953-220	3	400	50/60	7,5	10,8
HR953-320	3	400	50/60	10,7	15,5
HR953-470	3	400	50/60	15,6	22,5

Characteristics of electric postheater

Model	Phase [pcs]	Voltage [V]	Frequency [Hz]	Rated input [kW]	Total current [A]
HR953-150	1	230	50/60	2,5	10,9
HR953-220	3	400	50/60	3,9	9,75
HR953-320	3	400	50/60	5,4	7,8
HR953-470	3	400	50/60	8,4	12,1

**Basic technical parameters of the heat recovery units:**

## Characteristics of water postheater

Model	Rated input [kW]	Outlet air temperature [°C]	Water pressure loss [kPa]	Air pressure loss [Pa]	Air flow [m <sup>3</sup> /h]	Connection diameter	Type of coil connections
HR953-150	11,65	37,9	4,2	16	1500	3/4"	female
HR953-220	17,56	38,6	4,9	15	2200	3/4"	female
HR953-320	25,48	38,5	7,5	16	3200	3/4"	female
HR953-470	39,54	39,8	8,7	14	4700	1"	female

\* For water temperature gradient 90/70 and inlet air temperature 15°C

**Correction coefficients of the powers of the hot water coil\***

Air inlet temperature [°C]	Water temperature gradient					
	90/70	85/65	80/60	75/55	70/50	65/45
0°C	1,24	1,15	1,06	0,97	0,89	0,80
5°C	1,16	1,07	0,98	0,90	0,81	0,72
10°C	1,08	0,99	0,90	0,82	0,73	0,64
15°C	<b>1,00</b>	0,91	0,82	0,74	0,65	0,56
20°C	0,92	0,83	0,74	0,66	0,57	0,48

\* To apply to the rated power in the characteristics of the hot water coil.

## Characteristics of water cooling

Type	Rated input [kW]*	Outlet air temperature [°C]	Water pressure loss [kPa]	Air pressure loss [Pa]	Air flow [m <sup>3</sup> /h]	Connection diameter	Type of coil connections
HR953-150	5,95	15,3	5,7	50	1500	3/4"	female
HR953-220	9,35	14,9	6,2	45	2200	1"	female
HR953-320	13,03	15,2	5,7	51	3200	1 1/4"	female
HR953-470	19,75	15,1	6,6	36	4700	1 1/4"	female

\* For water temperature gradient 7/12 and inlet air temperature 25°C/RH 50%.

**Correction coefficients of the powers of the cool water coil (C/O)\***

Air inlet temperature [°C]	Water regime		
	7/12	6/11	5/10
25	<b>1,00</b>	1,11	1,22
24	0,88	0,99	1,10
28	1,39	1,50	1,61
32	1,94	2,06	2,16

\* To apply to the rated power in the characteristics of the water coil.



**Characteristics of direct evaporator (DX) - cooling**

Refrigerant R32

Type	Air flow [m³/h]	Rated input [kW]*	Outlet air temperature [°C]	Refrigerant pressure loss [kPa]	Air pressure loss [Pa]	Connection diameter of gas coil [mm]	Connection diameter of liquid coil [mm]	Internal coil volume [l]
HR953-150	1500	9,49	14,2	43,2	46	16	16	2,6
HR953-220	2200	13,66	14,4	23,7	44	16	22	3,6
HR953-320	3200	19,29	14,7	37,5	52	22	22	4,7
HR953-470	4700	29,83	14,2	61,4	40	2x 16	2x 16	8,0

\* For entering air temperature 27 °C, 47% RH, evaporating temperature 5°C, condensing temperature 45°C, subcooling 3K, superheating 7K

**Characteristics of direct condenser (DX) - heating**

Refrigerant R32

Type	Air flow [m³/h]	Rated input [kW]*	Outlet air temperature [°C]	Refrigerant pressure loss [kPa]	Air pressure loss [Pa]	Connection diameter of gas coil [mm]	Connection diameter of liquid coil [mm]	Internal coil volume [l]
HR953-150	1500	11,97	36,6	18,4	35	16	16	2,6
HR953-220	2200	17,24	36,2	10,1	33	16	22	3,6
HR953-320	3200	24,37	35,5	15,7	40	22	22	4,7
HR953-470	4700	36,74	36,1	29,5	30	2x 16	2x 16	8,0

\* For entering air temperature 13 °C, condensing temperature 45°C, subcooling 3K, superheating 25K

Type	Weight [kg]									
	Without preheater					With preheater				
	without coil -XS0S	electric heater -XE1S	hot water -XV1S	Water cooling/heating -XVCS	DX -XD3S	without coil -ES0S	electric heater -EE1S	hot water coil -EV1S	Water cooling/heating -EVCS	DX coil -ED3S
HR953-150	300	304	304	311	309	302	306	306	313	311
HR953-220	411	417	418	430	425	415	421	422	434	429
HR953-320	612	619	621	636	631	617	624	626	641	636
HR953-470	859	870	870	892	885	866	877	877	899	892



**DIMENSIONS**

HR953-150UP

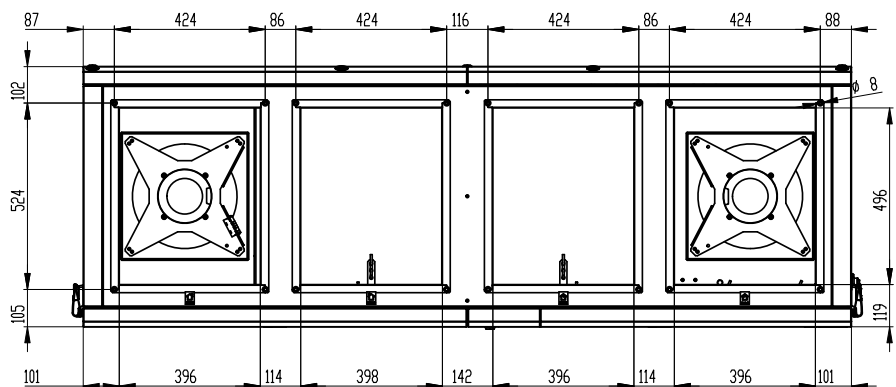
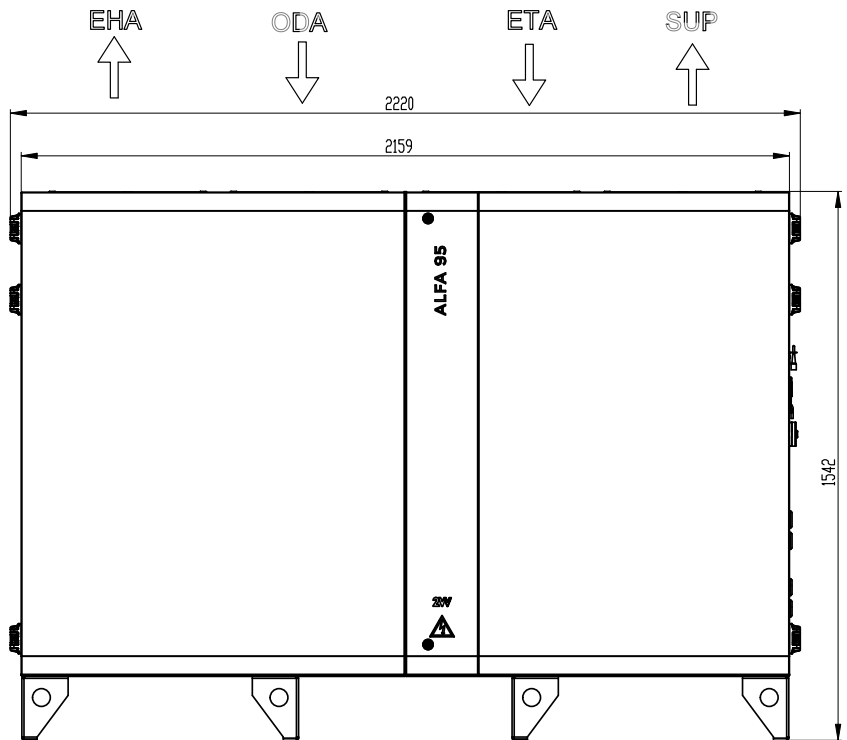
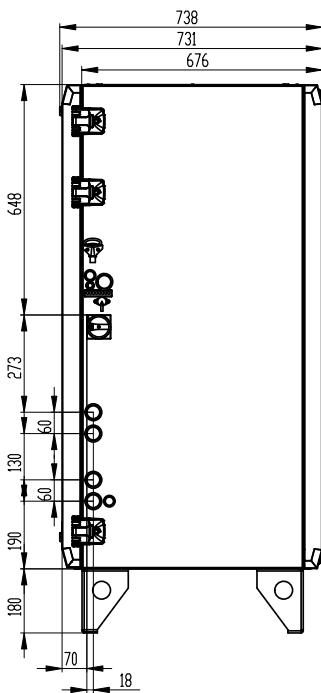
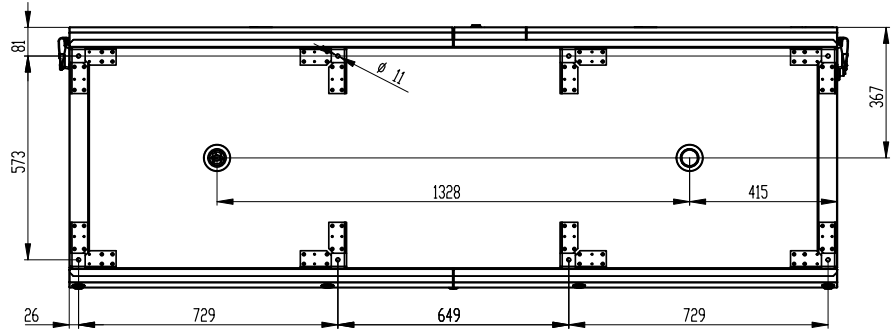



### DIMENSIONS

HR953-150UL

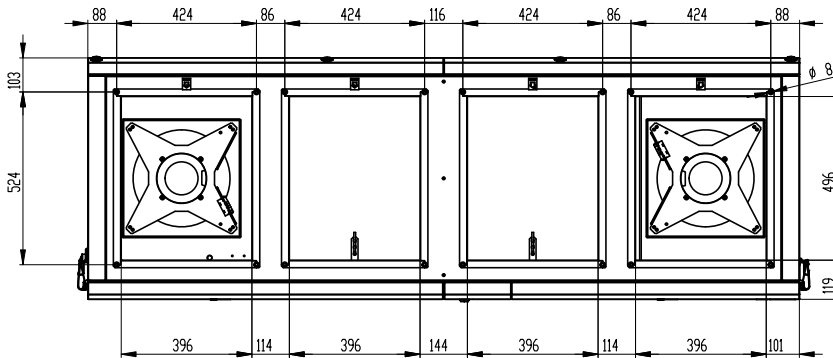
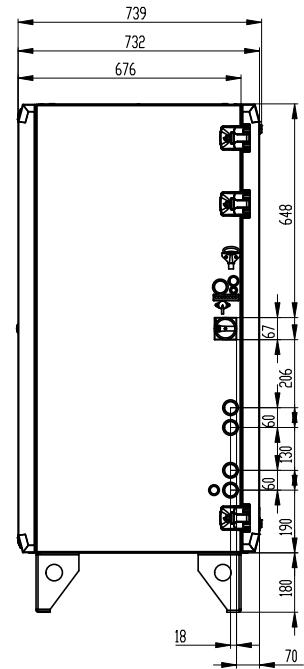
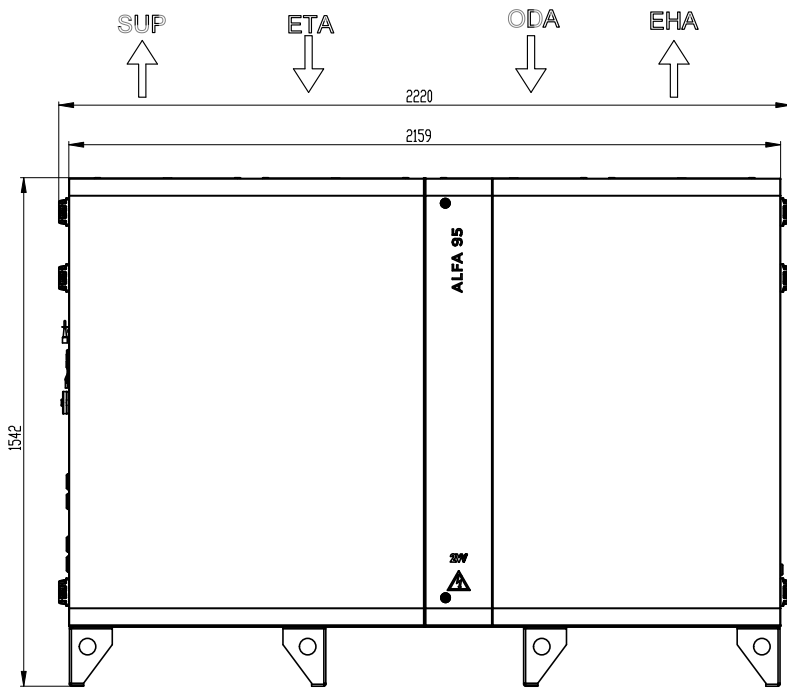
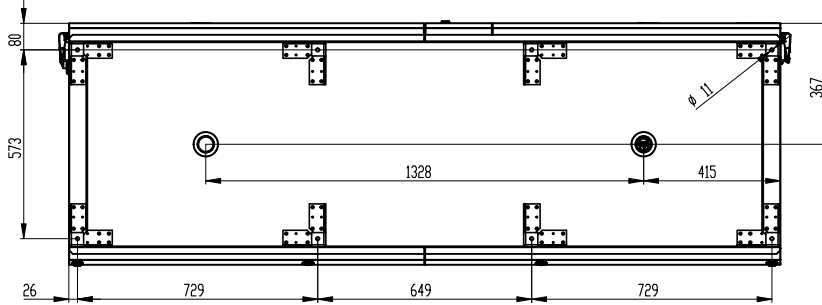



**DIMENSIONS**

HR953-220UP

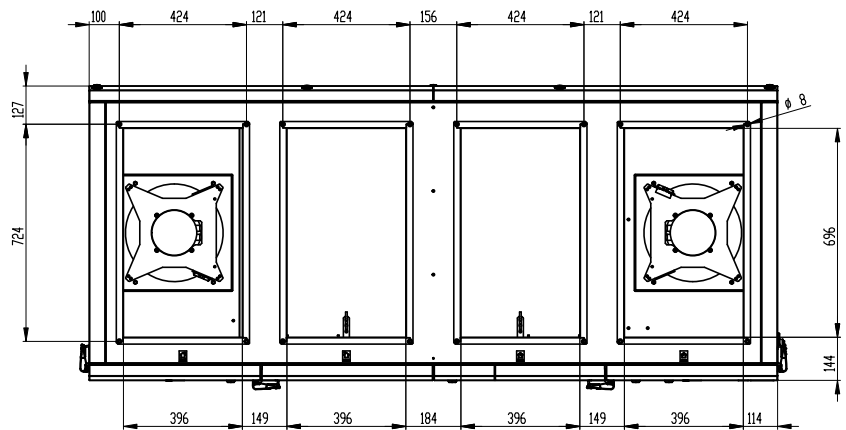
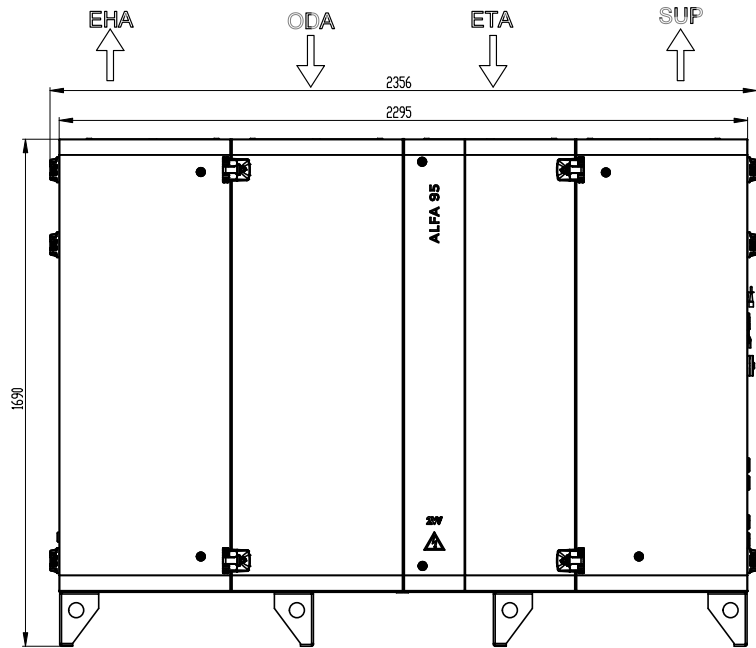
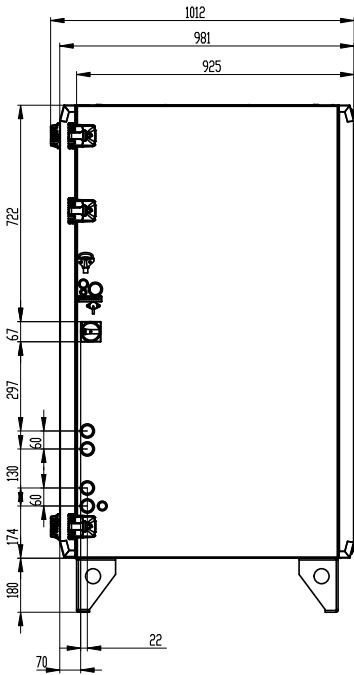
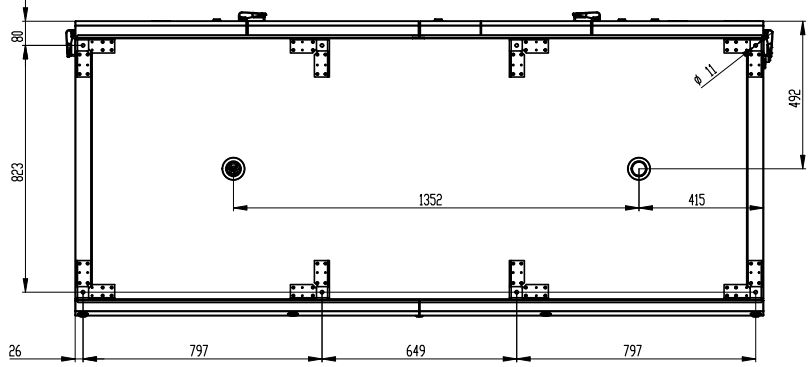



### DIMENSIONS

HR953-220UL

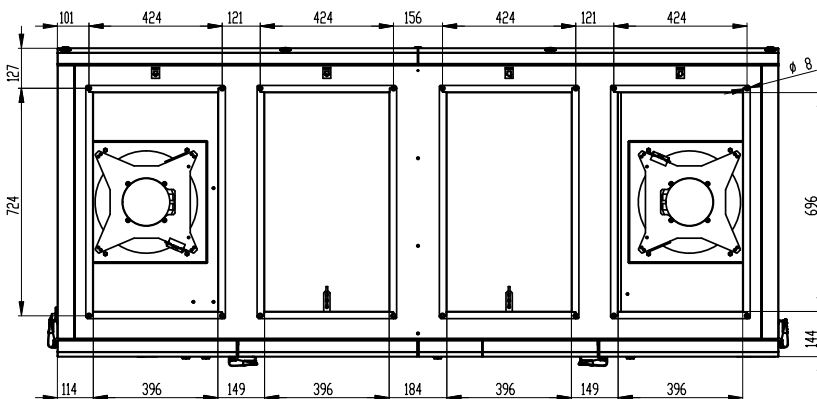
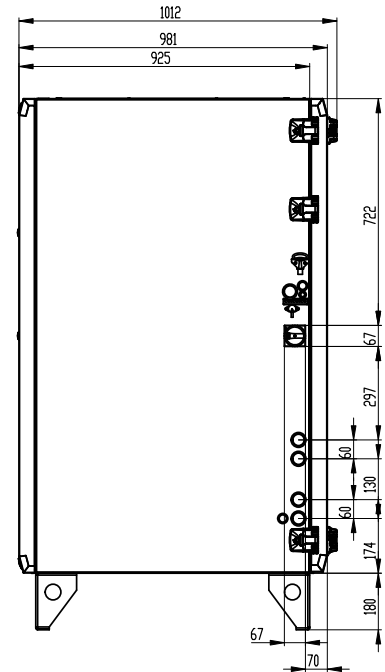
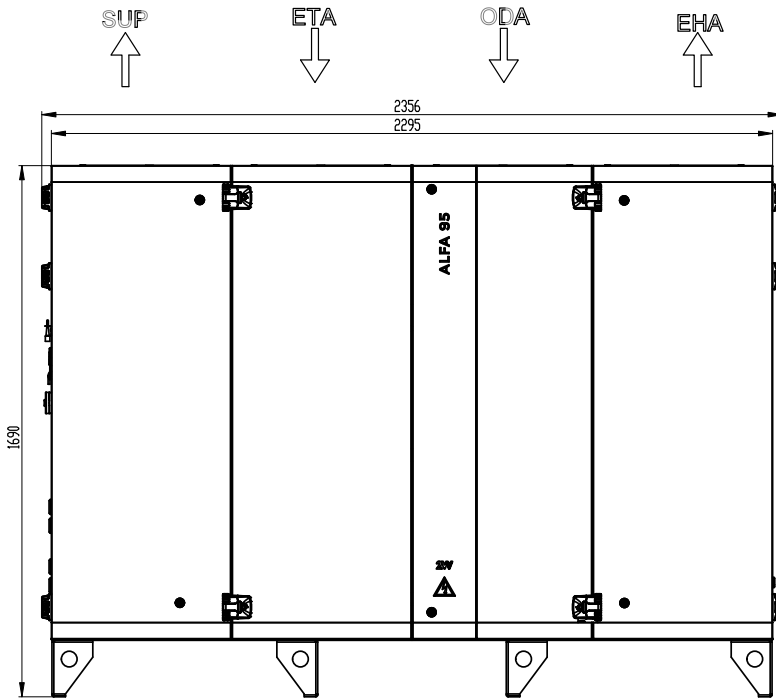
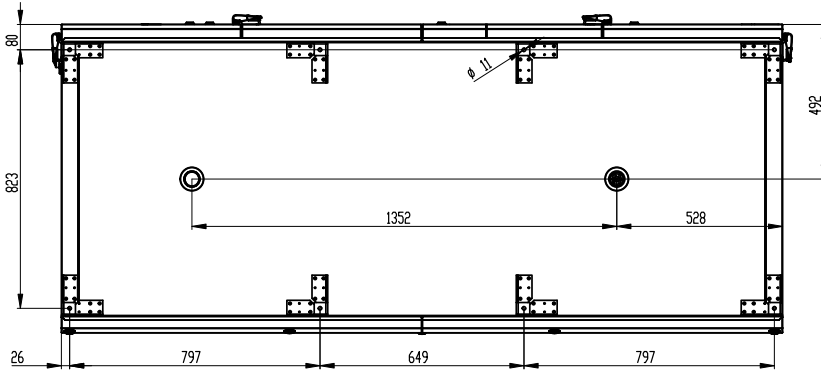





**DIMENSIONS**

HR953-320UP

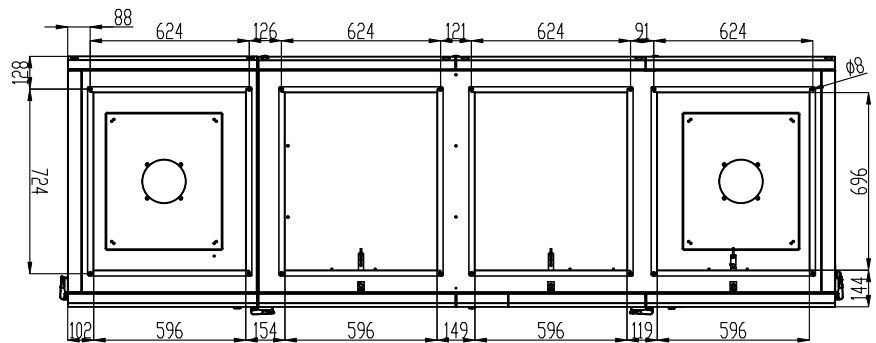
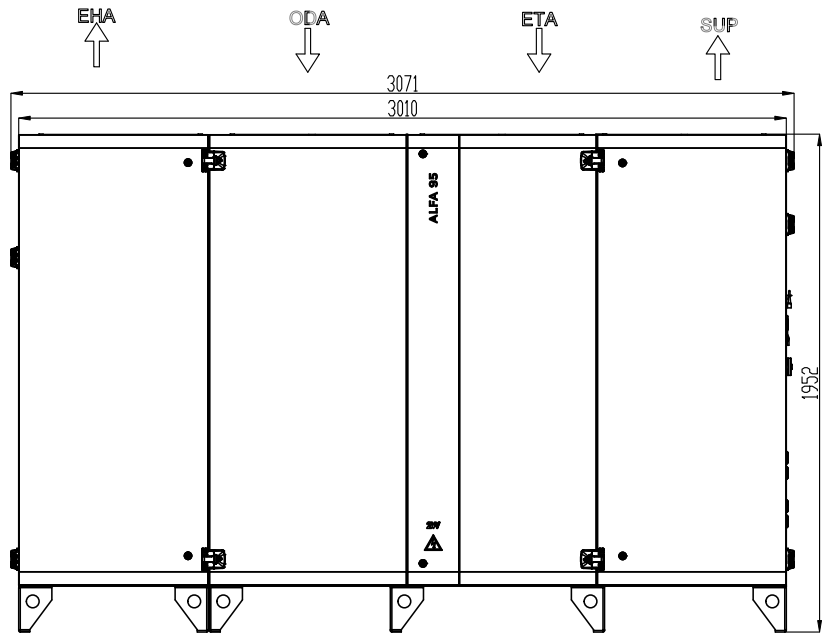
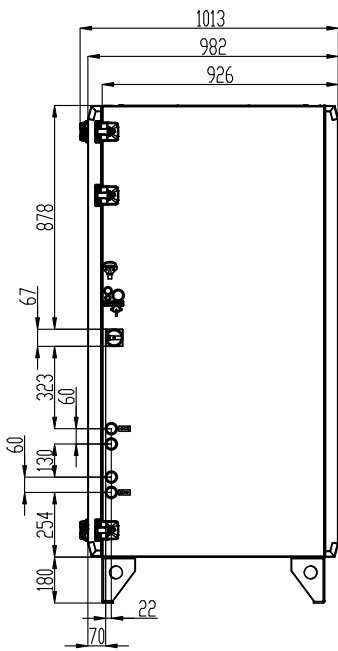
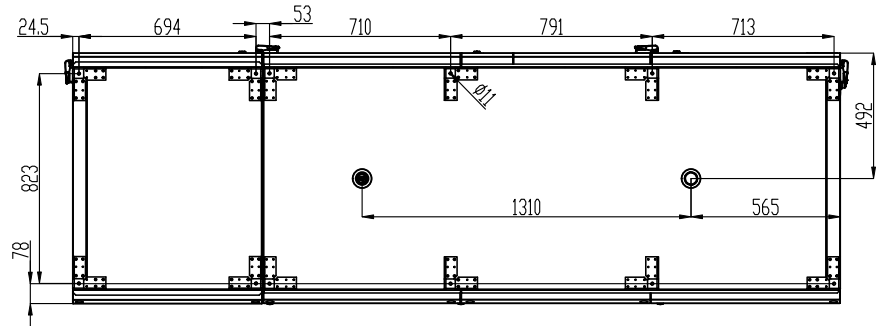



### DIMENSIONS

HR953-320UL

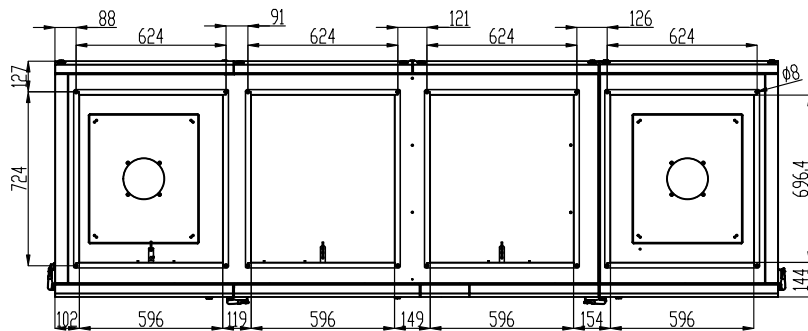
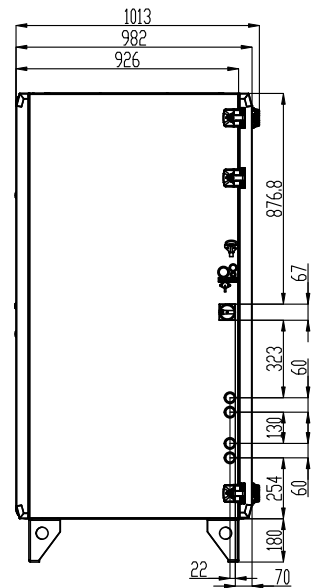
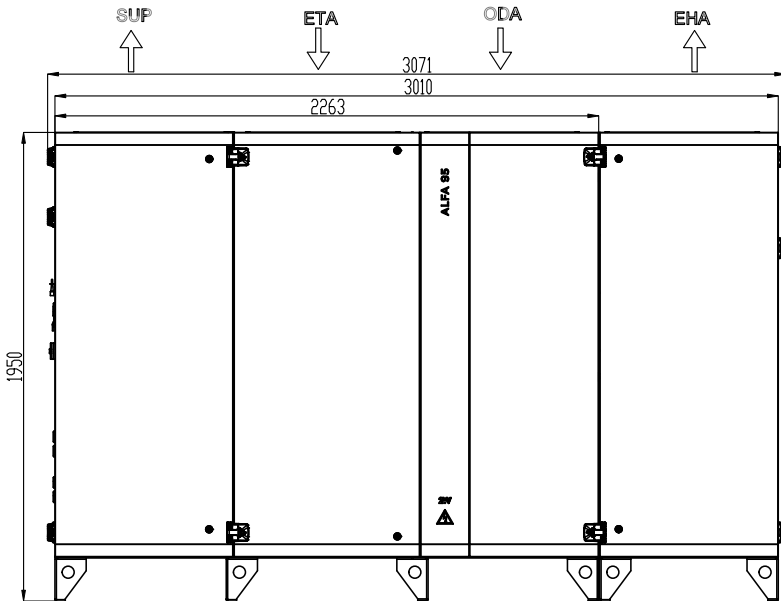
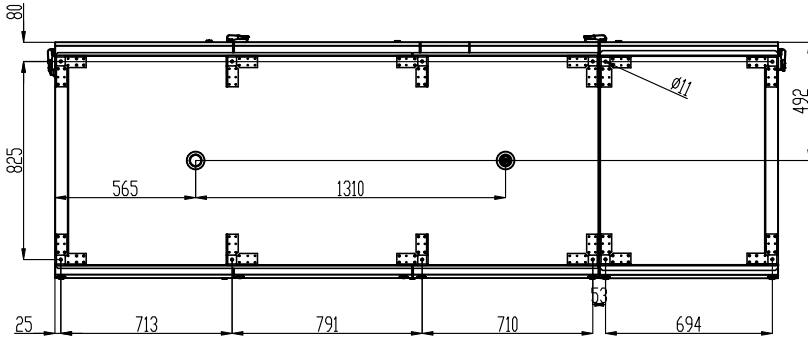



**DIMENSIONS**

HR953-470UP

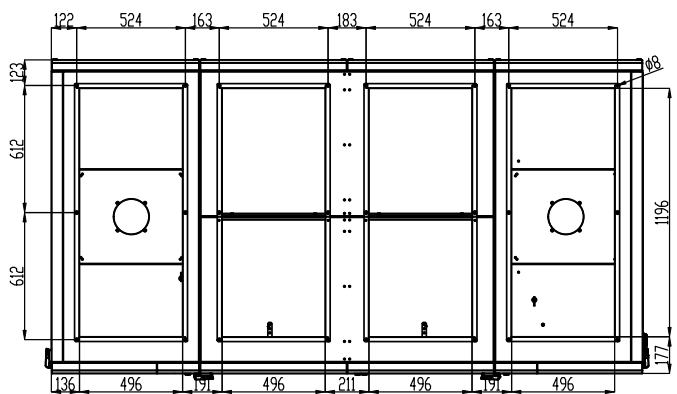
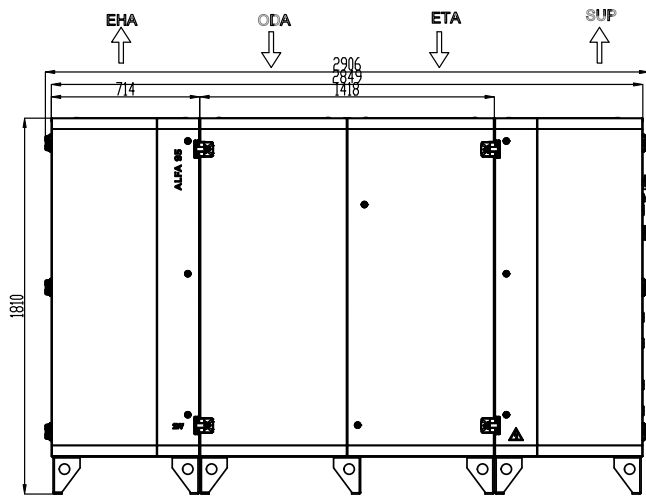
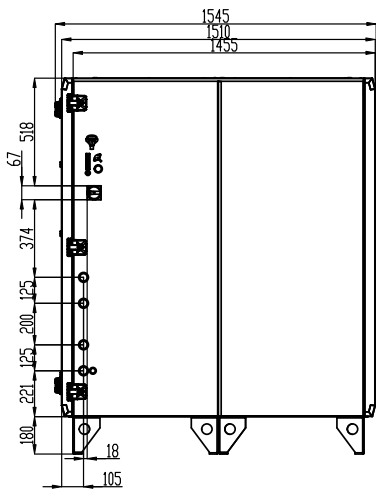
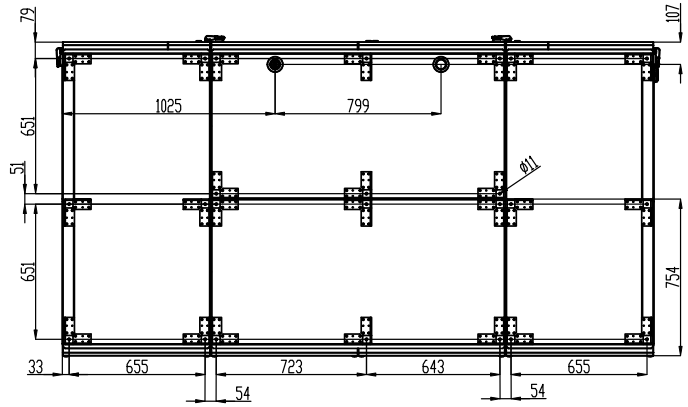



**DIMENSIONS**

HR953-470UL

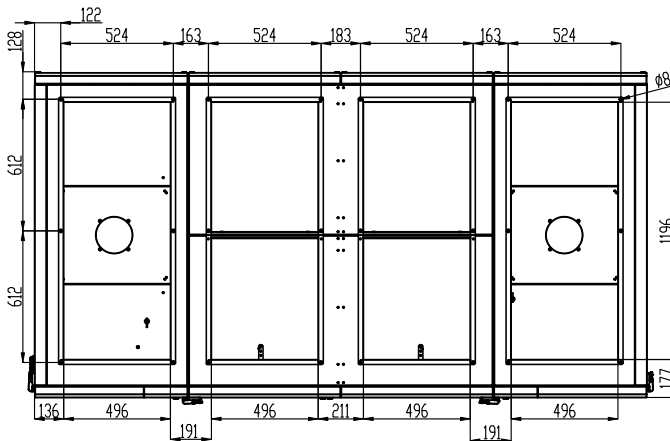
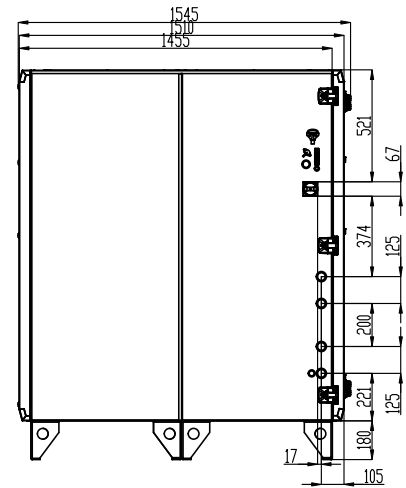
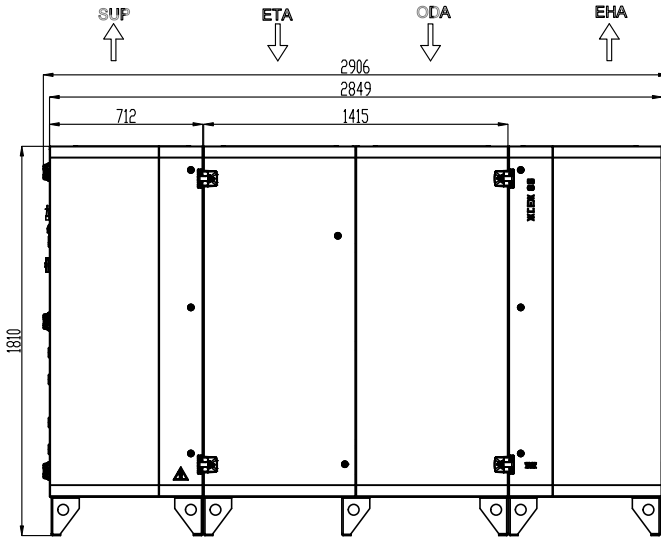
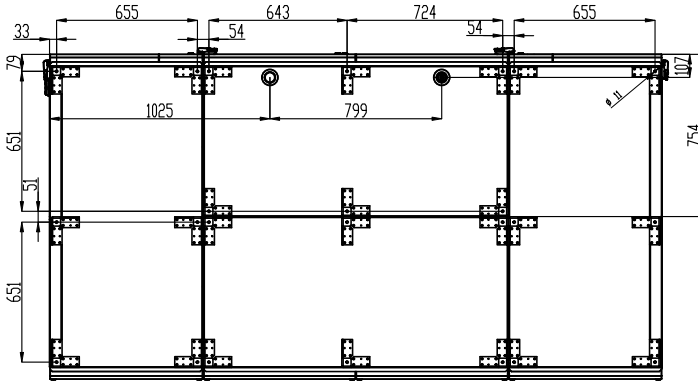

**INSTALLATION AND ASSEMBLY**

All vertical types of ventilation units must be installed according to the pictures (see below).

The unit must be installed in such a way that the direction of the air blown corresponds to the direction of air circulation in the distribution system. The unit must be installed so as to give free access for maintenance, service or dismantling. This is to allow access to service doors and possibility to open them, access to the lid of the control panel, access to the lateral connections and access to the filter cover.

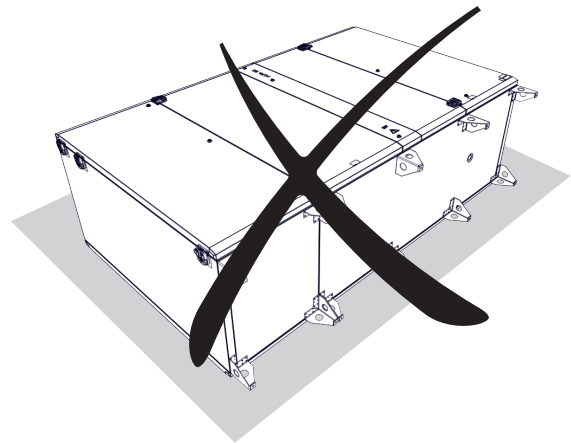
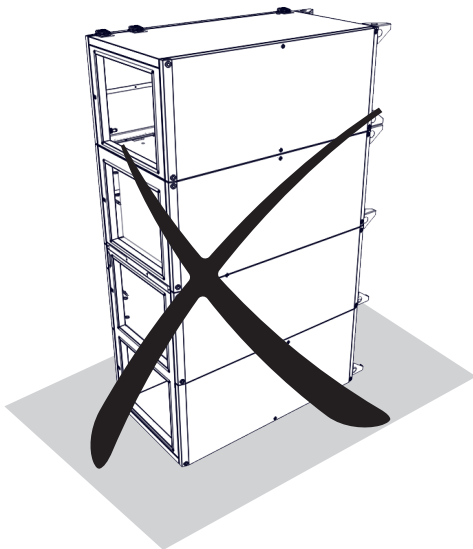
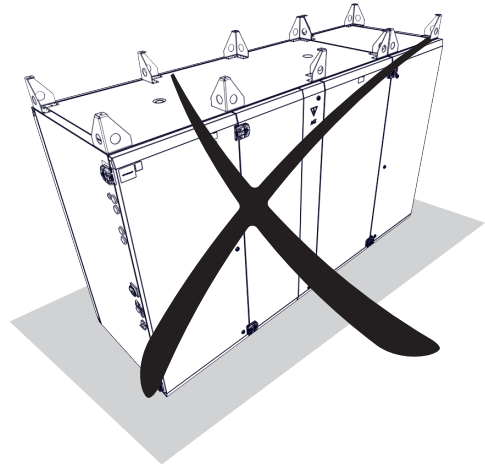
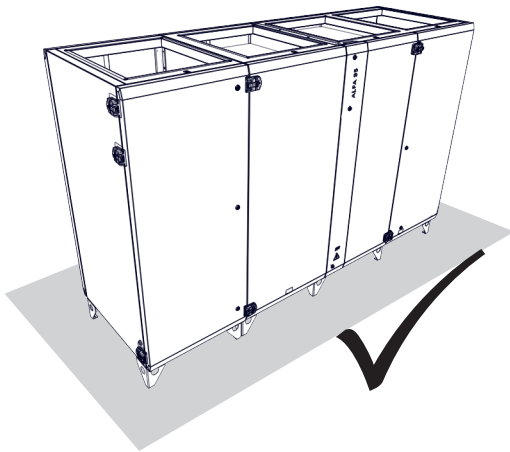



### WIRING DIAGRAMS

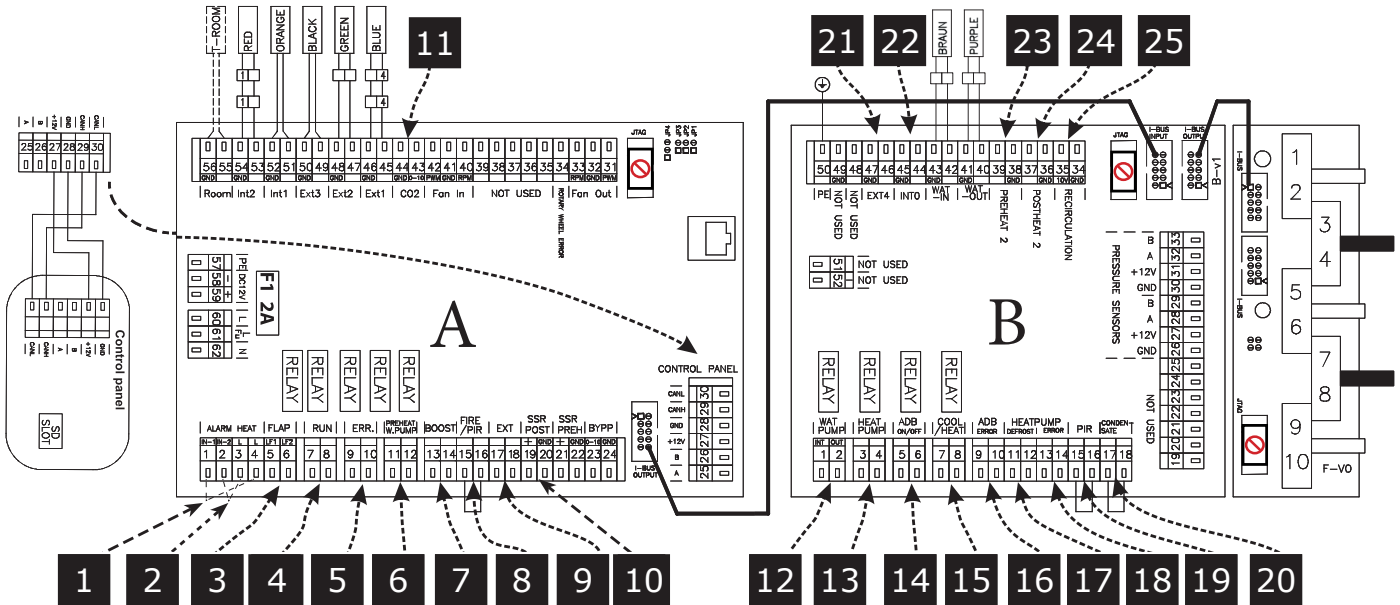

1	A (1,4)	Safety thermostat postheating
2	A (2,3)	Safety preheating thermostat
3	A (5-6)	LF1 - FLAP INLET (output L-open), LF2 - FLAP OUTLET ( output L-open)
4	A (7-8)	RUN CONTACT (output - NO/NC settable)
5	A (9-10)	ERROR CONTACT (output NO)
6	A (11-12)	PREHEATER WATER PUMP (11 - Lint, 12 - Lout)
7	A (13-14)	BOOST (input NO)
8	A (15-16)	FIRE (input NC)
9	A (17-18)	EXTERNAL CONTROL ON/OFF (input NC)
10	A (19,20)	OUTPUT PERFORMANCE OF POSTHEATING (0-10V OR PWM)
11	A (43-44)	AQS SENSOR 0-10V (input)
12	B (1-2)	WATER PUMP (1 - Lint, 2 - Lout)
13	B (3-4)	HEAT PUMP CONTROL settable (output - ON/OFF)
14	B (5-6)	ADIABATIC MODULE (output - ON/OFF)
15	B (7-8)	COOL / HEAT settable (CO = NC/NO - DX = output settable)
16	B (9-10)	ADIABATIC MODULE ERROR (input NO)
17	B (11-12)	HEAT PUMP DEFROST settable (input NC/NO)
18	B (13-14)	HEAT PUMP ERROR settable (input NC/NO)
19	B (15-16)	PIR (input NC)
20	B (17-18)	CONDENSATE OVERFLOW (input NC)
21	B (46-47)	EXTERNAL TEMPERATURE SENSOR (external postheater - input)
22	B (44-45)	EXTERNAL TEMPERATURE SENSOR (adiabatic module / recirc. chamber - input)
23	B (38-39)	EXTERNAL PREHEATER (output 0-10V)
24	B (36-37)	EXTERNAL POSTHEATER (output 0-10V)
25	B (34-35)	RECIRCULATION CHAMBER (output 0-10V)



**CONTROL**

**AirGENIO SUPERIOR - Main control functions**

- Touch-screen control panel for easy control and complete overview of device operational status (recommended connecting data cable to control panel is UTP cable and it should not exceed 50m length).
- Manual stepless fans control (PWM)
- CAV, VAV or DCV ventilation in automatic mode
- BOOST mode - intensive airflow for a pre-set time period
- Freecooling mode - night ventilation (cooling)
- Occupancy mode - reducing ventilation intensity according to the PIR sensor
- FIRE protection mode with settable logic
- Thermal wheel control (temperature control: freecooling, antifreeze protection)
- Integrated timer (day, week, year)
- Optional connection of sensors: CO<sub>2</sub>, RH, VOC (0-10)
- Clogged filter indication by pressure sensors
- Stepless post-heating control
- Electric coil control (PWM) and LPHW coil control (0-10 V)
- Change-over control with automatic detection of the heating / cooling (0-10 V)
- Wide choice of different ways for DX coil control\*
- Possible control of external pre-heater and post-heater
- Offset fan adjustment (over-pressure / underpressure)
- BMS control via Modbus RTU / TCP or BACnet
- Remote control via smart device



**\*AirGENIO SUPERIOR control system allows a different ways of DX coil control**

- ON-OFF
- 0-10 V
- 0-10 V - 0-10 V signal control
- On/Off - On/Off switching
- Off/On - Off/On switching
- 0-10 V + On/Off - On/Off switching + 0-10 V signal control
- 0-10 V + Off/On - Off/On switching + 0-10 V signal control

With reverse control cycle (heating - cooling mode)

- 10-0 V + On/Off - On/Off switching + 0-10 V signal control cooling, heating 10-0 V
- 10-0 V Off/On - Off/On switching + 0-10 V signal control cooling, heating 10-0 V

**2VW Service software:**

- Easy and quick commissioning from your computer
- Error log – error display and identification
- Easy service (device status loading/reset to backup setting)
- Fast FW update
- OFFLINE version

**AirGENIO CLOUD - Connections you can trust**

2VW cloud service operated on secure cloud server.

- Control, monitoring and servicing
- Web communication interface with clear and structured layout
- Easy customization of settings
- History logs providing accurate and timely info
- Smart notifications and warning/error messages clearly displayed in overview dashboard
- Backup and restore settings

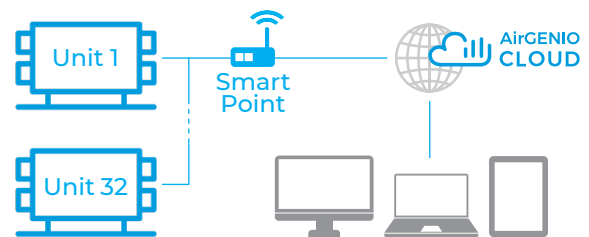



### ACCESSORIES

More details can be found on the relevant page in this catalog

#### Four-sided closing flap with servo drive

The **MLKR** rectangular control flap is designed for controlling and closing the HVAC systems. The flap is designed for operation in the basic environment for conveying air free of rough dust, grease, chemical fumes, and other contaminants. The flanged damper frame and blades are made of galvanized plate.

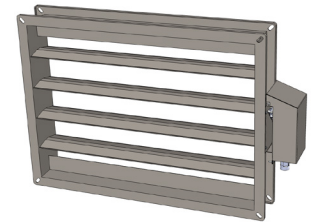

Unit type	Four-sided closing flap with servo drive
HR953-150U	MLKR-0500-0400-SR*
HR953-220U	MLKR-0700-0400-SR*
HR953-370U	MLKR-0700-600-SR*
HR953-450U	MLKR-1200-500-SR*

\* **SR** - servodrive with spring, **SX** - servodrive without spring

#### Adapter four-sided to circular

**PR-O** – adapter from four-sided to circular pipes made from a galvanised metal sheet

Unit type	Circular adapter
Vertical	
HR953-150U	PR-O-0500X0400-D500-L300
HR953-220U	PR-O-0700X400-D500-L400
HR953-370U	PR-O-0700x600-D560-L400
HR953-450U	PR-O-1200-500-D500-L600



#### Filtration inserts

**FILTR-HR953** – replacement filtration inserts of various filtration classes and configurations.



Unit type	Inlet pre-filter type – Coarse 60% Standard	Inlet filter type – ePM 1 50% Standard	Inlet filter type – ePM 1 80% Option	Extract filter type – ePM 10 50% Standard
HR953-150U	HR953-150U-FI-G4-0A0	HR953-150U-FI-F7-0A0	HR953-150U-FI-F9-0A0	HR953-150U-FI-M5-0A0
HR953-220U	HR953-220U-FI-G4-0A0	HR953-220U-FI-F7-0A0	HR953-220U-FI-F9-0A0	HR953-220U-FI-M5-0A0
HR953-370U	HR953-320U-FI-G4-0A0	HR953-320U-FI-F7-0A0	HR953-320U-FI-F9-0A0	HR953-320U-FI-M5-0A0
HR953-450U	HR953-470U-FI-G4-0A0	HR953-470U-FI-F7-0A0	HR953-470U-FI-F9-0A0	HR953-470U-FI-M5-0A0



**Mixing valve**

The **SMU** mixing unit is designed for controlling the heat-output of water-type heat exchangers. It is used especially for controlling standalone water-type air heaters, heaters inbuilt into the ventilation units

Recommended values for individual types of the **ALFA 95** units:

**SMU2-024-06,3-SC**

- SC** - with short circuit
- WO** - without short circuit
- 00,6** - mixing valve -  $k_{VS}$  0,6
- 01,6** - mixing valve -  $k_{VS}$  1,6
- 02,5** - mixing valve -  $k_{VS}$  2,5
- 04,0** - mixing valve -  $k_{VS}$  4,0
- 06,3** - mixing valve -  $k_{VS}$  6,3
- 12,0** - mixing valve -  $k_{VS}$  12,0
- 24,0** - mixing valve -  $k_{VS}$  24,0

**024** - 24V stepless control

**SMU2** - mixing unit

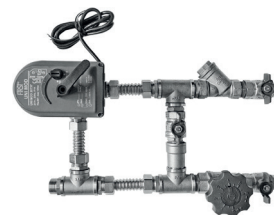
**Condensate siphon****SK-AKS3**

Ball Siphon for direct connection to the unit.





**Channel sensor CO<sub>2</sub>**  
**CI-EE850-C3xx-FP**

The transmitter is ideally suited for duct mounting in the fields of building management and demand controlled ventilation. The elegant, compact housing enables easy installation directly at the ventilation duct using a mounting flange.



**Duct sensor of relative humidity**  
**CI-LCN-FTK140VV**

Duct sensor for measuring relative humidity in air-conditioning systems.



**Spatial sensor CO<sub>2</sub>**  
**CI-CO2-R**

Sensor combines CO<sub>2</sub>. The snap-in mounting concept stands for easy installation.



**Spatial sensor RH**  
**CI-RH-R**

Capacitive relative humidity sensor with 0-10V analog and relay output.



**Signal combiner**  
**CI-AQS-COMBI**

The signal combiner for AQS sensors uses 0-10V logic which you can connect up to 10 different sensors. The input signal with the highest voltage will be the signal that is on the output terminal.



**PIR sensor**  
**CI-PS 1003**

Spatial infrared sensor for automatic ventilation based on presence of people in the ventilated area.

**Power supply of this sensor must be outsourced. Unit doesn't support this kind of power supply (15-24V DC).**



**AirGENIO CLOUD smart point**  
**AirGENIO-SMART-POINT**

2WV cloud service operated on secure cloud server





**KEY TO CODING**

**HR953- 150 V P CB E 7 5- E S0 S- 0A 0**

- 0** - 2V version
- A** - monoblock/modular units packed as monoblock (assembled)
- B** - modular units packed each module individually
- S** - SUPERIOR AirGENIO control
- S0** - Without post-heater
- E1** - With el. post-heater
- V1** - Water post-heater
- VC** - Water heater / Cooler - 4pipe system
- D4** - DX post-heater
- X** - Without pre-heater
- E** - With el. pre-heater
- 5** - Extract filter ePM 10 50%
- 7** - Inlet filter ePM1 ≥ 50%
- E** - EC fans
- S** - EC fans SUBSTITUTION of standard (not to be part of official sales offer)
- CB** - Counterflow with by-pass
- EB** - Entalpic counterflow with by-pass
- P** - Right
- L** - Left
- U** - Upper outlets
- 150** - Nominal flow rate 1500m3/h
- 220** - Nominal flow rate 2200m3/h
- 320** - Nominal flow rate 3200m3/h
- 470** - Nominal flow rate 4700m3/h

Heat recovery unit **ALFA 95 3<sup>rd</sup> generation**